



Standard Guide for Use of Silicone Sealants for Protective Glazing Systems¹

This standard is issued under the fixed designation C 1564; the number immediately following the designation indicates the year of original adoption or, in the case of revision, the year of last revision. A number in parentheses indicates the year of last reapproval. A superscript epsilon (ϵ) indicates an editorial change since the last revision or reapproval.

1. Scope

1.1 This guide covers the use of silicone sealants in protective glazing systems for building construction. Protective glazing includes systems designed for use in applications subject to natural disasters such as hurricanes, earthquakes, windstorms and forms of forced entry such as blasts, burglary, and ballistic attack.

1.2 While other glazing accessories and components are used in protective glazing, this document specifically describes the use of silicone sealants for protective glazing systems.

1.3 This guide provides information useful to design professionals, architects, manufacturers, installers, and others for the design and installation of silicone sealants for protective glazing systems.

1.4 A silicone sealant is only one component of a glazing system. A glazing system that meets the testing and code requirement for impact glazing must successfully integrate the frame and its anchorage, glass, or other glazing materials, protective film or interlayer and silicone sealant into a high performance system. Compliance with code or other requirements can be determined through physical testing of the glazing system or through computer simulation.

1.5 Glazing systems using silicone sealants that have successfully met the test requirements for missile impact and bomb blast test requirements incorporate the use of silicone sealants specifically formulated, tested, and marketed for this application. Sealants that are commonly used today comply with Specifications C 920 and C 1184.

1.6 This guide does not discuss sealants intended to protect against radioactivity or provide biological containment.

1.7 The committee with jurisdiction over this standard is not aware of any comparable standards published by other organizations.

1.8 *This standard does not purport to address all of the safety concerns, if any, associated with its use. It is the responsibility of the user of this standard to establish appropriate safety and health practices and determine the applicability of regulatory requirements prior to use.*

¹ This guide is under the jurisdiction of ASTM Committee C24 on Building Seals and Sealants and is the direct responsibility of Subcommittee C24.10 on Specifications, Guides, and Practices.

Current edition approved February 1, 2004. Published March 2004. Originally approved in 2003. Last previous edition approved in 2003 as C 1564 – 03a.

2. Referenced Documents

2.1 ASTM Standards:²

- C 717 Terminology of Building Seals and Sealants
- C 719 Test Method for Adhesion and Cohesion of Elastomeric Joint Sealants under Cyclic Movement (Hockman Cycle)
- C 794 Test Method for Adhesion-in-Peel of Elastomeric Joint Sealants
- C 920 Specification for Elastomeric Joint Sealants
- C 1087 Test Method for Determining Compatibility of Liquid-Applied Sealants with Accessories Used in Structural Glazing Systems
- C 1135 Test Method for Determining Tensile Adhesion Properties of Structural Sealants
- C 1184 Specification for Structural Silicone Sealants
- C 1193 Guide for Use of Joint Sealants
- C 1394 Guide for In-Situ Structural Silicone Glazing Evaluation
- C 1401 Guide for Structural Sealant Glazing
- C 1472 Guide for Calculating Movement and Other Effects When Establishing Sealant Joint Width
- D 624 Test Method for Tear Strength of Conventional Vulcanized Rubber and Thermoplastic Elastomers
- E 631 Terminology of Building Construction³
- E 1886 Test Method for Performance of Exterior Windows, Curtain Walls, Doors and Storm Shutters Impacted by Missile(s) and Exposed to Cyclic Pressure Differentials
- F 1642 Test Method for Glazing and Glazing Systems Subject to Airblast Loadings

2.2 GSA Standard:

- US General Services Administration (GSA) Standard Test Method for Glazing and Window Systems Subject to Dynamic Overpressure Loading⁴

3. Terminology

3.1 *Definitions*—Refer to Terminologies C 717 and E 631 for definitions of terms used in this guide.

² For referenced ASTM standards, visit the ASTM website, www.astm.org, or contact ASTM Customer Service at service@astm.org. For *Annual Book of ASTM Standards* volume information, refer to the standard's Document Summary page on the ASTM website.

³ Withdrawn.

⁴ U.S. General Services Administration (GSA), 1800 F Street, NW Washington, DC 20405

4. Significance and Use

4.1 Guidelines are provided for the use of silicone sealants in protective glazing. Protective glazing incorporates various forms of glazing that are not covered in Guides C 1401 and C 1193. The requirements for a sealant in protective glazing are similar to the requirements for structural sealant glazing but for certain applications such as missile impact and bomb blast glazing, sealant requirements may be greater. Modes of failure for bomb blast glazing can be different than the modes of failure for missile impact glazing.

4.2 Many types of protective glazing systems are relatively new and the test methods and standards for protective glazing are continually evolving. Because the demands on a sealant in protective glazing systems are changing, guidelines are necessarily general in many instances.

4.3 As a component of a glazing system, the sealant can be a factor in whether a glazing system meets the requirements of a specific test method but other factors such as the frame and glass type may be of greater influence.

4.4 The designer of a protective glazing system should consult with the various manufacturers of the component materials. The experience and judgment of the glazing system designer working with the sealant manufacturer and other component manufacturers can ultimately determine whether a specific glazing system will successfully meet a specific test requirement.

5. Introduction

5.1 Protective glazing systems are designed for the protection of the building occupants and general public from various natural and man-made occurrences that could cause injury or damage. Natural disasters include hurricanes, earthquakes, and windstorms, which with their high winds and wind-driven rain can cause failure to joint sealants. Additionally, flying debris resulting from high winds can cause damage to the glazing system. Test methods such as Test Method E 1886 simulate the effect of flying debris during a windstorm. Man-made occurrences include bomb blast, ballistic attack, burglary, and vandalism. Test methods such as Test Method E 1886 and GSA Standard Test Method for Glazing and Window Systems Subject to Dynamic Overpressure Loading provide procedures for the testing of glazing systems subject to bomb blast. Computer software programs such as WINGARD or WINLAC may be used to evaluate the effects of a bomb blast on a glazing system.

5.2 A sealant can play a crucial role in retaining the glazing material in the opening and thus preserving the integrity of the building envelope. If the building envelope is lost due to failure of the glazing system, the building can become pressurized resulting in significant damage to the structure, its contents and its occupants. The type of framing system, glazing material(s), and sealant are major components of a glazing system that must meet demanding test requirements and that considered separately may or may not have a significant impact on system performance.

6. Sealant Considerations

6.1 Depending on the specific requirement of the protective glazing system, the properties of the sealant can perform a

significant role in the overall performance of the system. Important properties to consider when selecting a sealant for any glazing system include the following:

6.1.1 *Adhesion*—Sealant adhesion should be confirmed as acceptable to the components of the glazing system including glass, glass coatings, metal, wood, plastic, film laminate, or other material to which adhesion is required. Adhesion can be determined using Test Methods C 794 or C 1135. The adhesion requirements specified in Specification C 1184 should be considered as the minimum requirement for most missile impact and bomb blast glazing systems. Guide C 1193 includes a discussion on adhesion and testing that may be helpful.

6.1.2 *Compatibility*—Sealant compatibility with each of the glazing components should be verified. Components include PVB, polycarbonate or a similar interlayer of laminated glass, insulating glass unit edge sealants, glazing and other gasket and spacer materials, and metal framing materials and factory applied coatings. Compatibility with gasket or other accessory materials is determined using Test Method C 1087. Guide C 1193 includes a discussion on compatibility and testing that may be helpful.

6.1.3 *Strength and Modulus*—Sealant strength and modulus are very important factors in determining whether a glazing system will pass a specific protective glazing requirement. A sealant with an ultimate tensile strength that is too low may not be able to support the glazing through a specific missile impact or bomb blast test requirement. As a guide, the strength and modulus requirements identified in Specification C 1184 should be followed. For some applications, such as encountered in certain bomb blast test requirements, these strength and modulus requirements may not be high enough and a higher strength structural silicone will be required. Since certain high modulus sealants have lower movement capability, considerations should be made to ensure that annual movement on the sealant joint does not exceed the movement capability of the sealant.

6.1.4 *Tear Characteristics and Fatigue*—Along with strength and modulus, the ability of a sealant to withstand the cyclic loading of certain protective glazing test methods is important. Tear strength as determined by Test Method D 624 can be useful in determining whether a sealant can withstand the impulse load of a blast test or the cyclic loading of a missile impact test. The ability of a sealant to withstand the fatigue associated with cyclic loading is an important consideration that may deem a sealant appropriate for missile impact applications.

6.1.5 *Durability*—Sealant durability is important in protective glazing. A sealant used in protective glazing is subject to a broad range of environmental factors including: Temperature cycling, solar radiation exposure, moisture from the environment or condensation, ozone, and airborne pollutants. These factors can cause premature failure of certain sealant types. Guide C 1193 includes a discussion on sealant durability and testing.

6.1.6 *Movement Capability*—The movement capability of a sealant is important if the sealant also serves as a weatherseal in a protective glazing system. Consideration of a sealant's movement capability is important for a glazing system to

remain watertight and function as intended. Environmental thermal cycling and other framing system movements may impact the ability of a sealant to perform as a weatherseal. Sealant joint design is important in determining if a sealant can perform as for a weatherseal. Test Method C 719 should be used to determine movement capability of a sealant. Guides C 1193 and C 1472 should be used to determine proper sealant joint design.

7. Design Considerations

7.1 Currently there are no industry-accepted standards for the design of sealant joints in protective glazing systems. The considerations discussed below are based on findings from actual tests of protective glazing systems according to Test Methods E 1886, F 1642, and GSA Standard Test Method for Glazing and Glazing Systems Subject to Airblast Loadings. Unlike structural glazing where joint dimensions can be calculated and precisely determined, this capability does not exist for the design of joints in protective glazing systems. Variables such as glass type and dimension, laminate type, framing system, anchoring, applied loads, and other factors will all have an impact on the performance of the sealant joint in a protective glazing system.

7.2 *Applied Loads*—Protective glazing that is designed to resist bomb blast criteria must also be designed to resist other lateral loads such as those required by the local building code, which usually include lateral wind loads and seismic events. For example, sometimes the design requirements for protective glazing to resist a bomb blast can differ from those for an applied lateral load from the local wind environment. Glass or a glass composite product with the necessary strength and deflection characteristics for a protective glazing system, when designed for bomb blast resistance, may not have the necessary strength and deflection characteristics to resist a building code or laboratory test determined wind load. The designer of a protective glazing system may have to consider both bomb blast and wind load requirements. Doing so may change the design requirements for at least the glazing product, glazing sealant joint, glazed opening metal framing, and framing anchorage requirements from those solely required for resisting a bomb blast.

7.3 *Joint Sizing and Dimensions*—As important as the selection of sealant is the geometry of the sealant joint in the glazing system. In a protective glazing system, the sealant joint may be either structural or non-structural. For a structural joint, the applicable requirements of Specification C 1184 and Guide C 1401 should be considered. For a non-structural application, the sealant does not act to structurally support the glazing under the influence of a wind-load but would be expected to retain the glazing in the framing system during the testing or during an actual event. In this respect, the sealant does act in a manner similar to a structural sealant and the properties of the sealant and design of the sealant joint are important. Bite and thickness are two terms used to describe the dimensions of a structural joint (see Guide C 1401). These terms also apply when describing a non-structural glazing system. The joint design must be sufficient to allow the joint surfaces to be

properly cleaned and allow adequate sealant application into the joint opening. See 8.3 for a discussion of sealant curing considerations.

7.3.1 *Structural Sealant Glazed Joint*—A silicone sealant may be used in a structural sealant glazed system that is also expected to meet certain protective glazing requirements. At least the bite and thickness minimum guidelines stated in Specification C 1184 and Guide C 1401 must be met. Glazing systems which have passed either small or large missile impact tests have bite dimensions of at least 12 mm ($\frac{1}{2}$ in.) and in some cases bite dimensions of 19 mm ($\frac{3}{4}$ in.) to 25 mm (1 in.) have been required. Other key factors affecting glazing system performance include glass selection, bite configuration, frame strength, and other factors. Currently, actual full-scale performance is used to establish appropriate bite or thickness dimension necessary to successfully pass a missile impact test. Typical structurally glazed systems designed to pass missile impact test requirements are shown in Figs. 1-3. Fig. 1 illustrates a typical system with monolithic glass lite with a laminate and polycarbonate coating on the interior facing surface of the glazing. Fig. 2 illustrates a conventional laminated glass. Fig. 3 illustrates a laminated insulating glass unit.

7.3.2 *Non-Structural Sealant Glazed Joint*—A sealant may also be used in a glazing system where it is not intended to support the glass structurally under windload. In protective glazing, the sealant serves the dual purpose as a weatherseal in the glazing system and as an anchor for the glazing in missile impact or blast testing. The sealant performs non-structurally prior to missile impact or blast and serves to anchor the glazing in the opening after it is broken. For this reason, a high strength structural sealant should be considered. In this design, sealant may be installed on the inside or outside, or both, surfaces of the glass. Conventional laminated glass typically requires sealant on both the inside and outside surface to successfully meet impact test requirements. For blast glazing, the laminated glass must be enclosed within the framing system to successfully pass the test requirements. As in a structurally glazed joint, there are no clear guidelines as to the appropriate bite and thickness requirements necessary to pass a missile impact or blast test. Systems that have successfully passed either test typically use sealant bite dimensions of between 12 to 25 mm ($\frac{1}{2}$ to 1 in.) with a thickness of 6 to 12 mm ($\frac{1}{4}$ to $\frac{1}{2}$ in.). Typical non-structurally glazed systems that have passed missile impact or blast test requirements are illustrated in Figs. 4-6. Fig. 4 illustrates a generic use of a monolithic glass lite with a laminate applied to the interior facing surface of the glass. Fig. 5 illustrates a generic use of a conventional laminated glass. Fig. 6 illustrates a generic use of a laminated insulating glass unit. See 8.3 for a discussion of sealant curing considerations.

7.3.3 *Fillet Joint for a Film Laminate*—As a method to retrofit existing glazing systems for impact resistance, a laminate film may be applied. The film is laminated to the interior surface of the glazing and a sealant is applied in a fillet bead configuration around the perimeter of the film. The sealant acts to anchor the film to the framing system and provides support during a hurricane, natural disaster, or impact event. The use of a sealant that meets the performance criteria of Specification

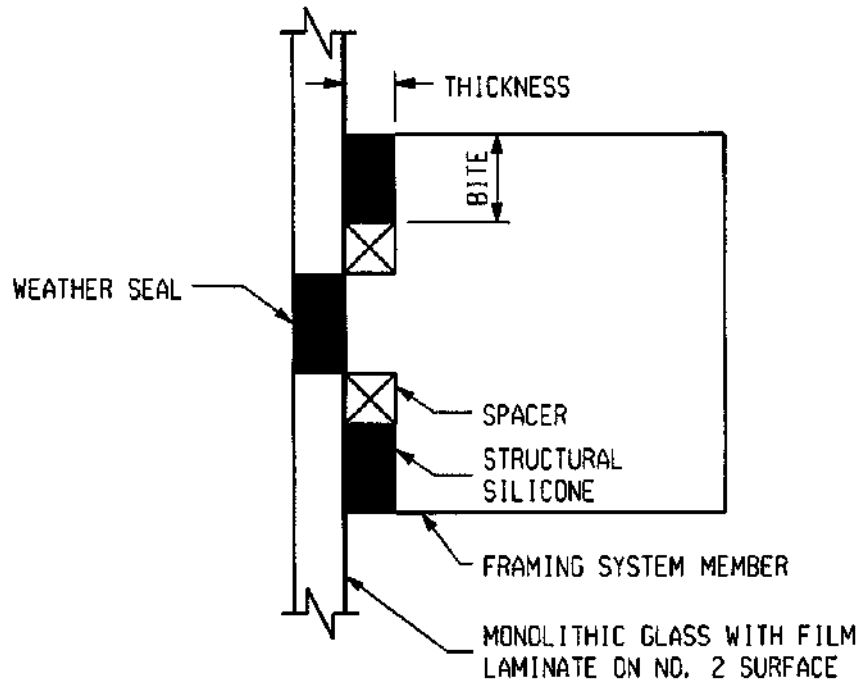

FIG. 1 Generic Missile Impact Detail with Monolithic Glass with Laminate

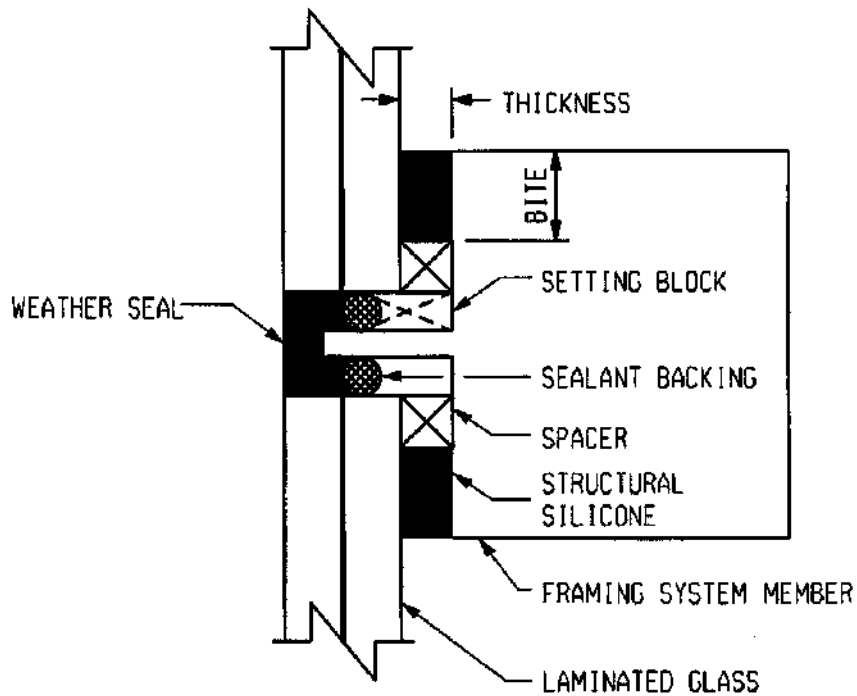

FIG. 2 Generic Missile Impact Detail with Laminated Glass

C 1184 should be considered in this design. Fig. 7 illustrates a typical sealant joint using a film laminate.

7.3.4 *Bedding Sealant for Residential Windows*—With the advent of missile impact requirements for residential windows, window manufacturers have revised the design of their glazing systems. To successfully meet missile impact test requirements, residential window manufacturers have adopted some

of the design concepts used by commercial window manufacturers. As a result, residential window design uses a sealant to not only weatherseal but also to anchor the glazing in the window sash. A higher strength sealant should be considered for use as a bedding sealant in the window sash. Fast-curing, one-part silicone sealant should be considered to provide the necessary production rates and physical properties to pass the

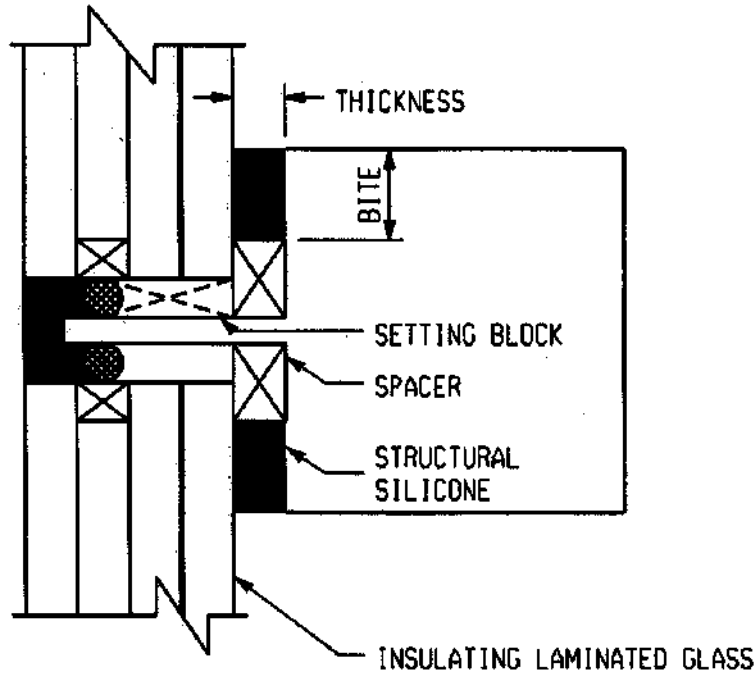

FIG. 3 Generic Missile Impact Detail with Insulating Laminated Glass

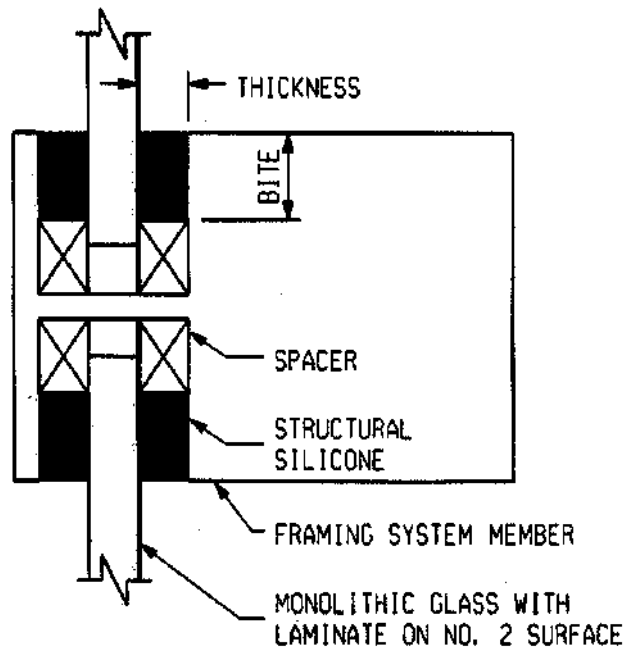

FIG. 4 Generic Missile Impact or Bomb Blast Detail with Monolithic Glass with Laminate

required testing. The sealants used in this type of application may not necessarily have the strength necessary to pass the requirements of Specification C 1184 but still allow the glazing system to meet the missile impact test requirements. A generic residential window detail is illustrated in Fig. 8.

8. Installation Considerations

8.1 General sealant installation is described in Guides C 1193 and C 1401. Appropriate sealant installation procedures

include a clear description of proper substrate cleaning, priming, sealant backing installation, sealant application, and sealant tooling. Joint opening dimensions must allow the joint surfaces to be properly cleaned and to permit the sealant to be properly installed and tooled in the joint. Consideration should be given to the following variables.

8.2 *Shop or Construction Site Installation*—Certain protective glazing system designs are appropriate for sealant installation at the construction site while others are appropriate for

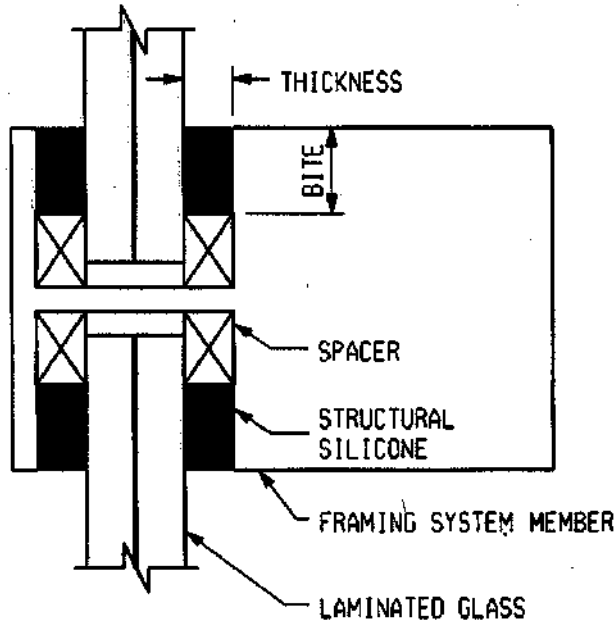

FIG. 5 Generic Missile Impact or Bomb Blast Detail with Laminated Glass

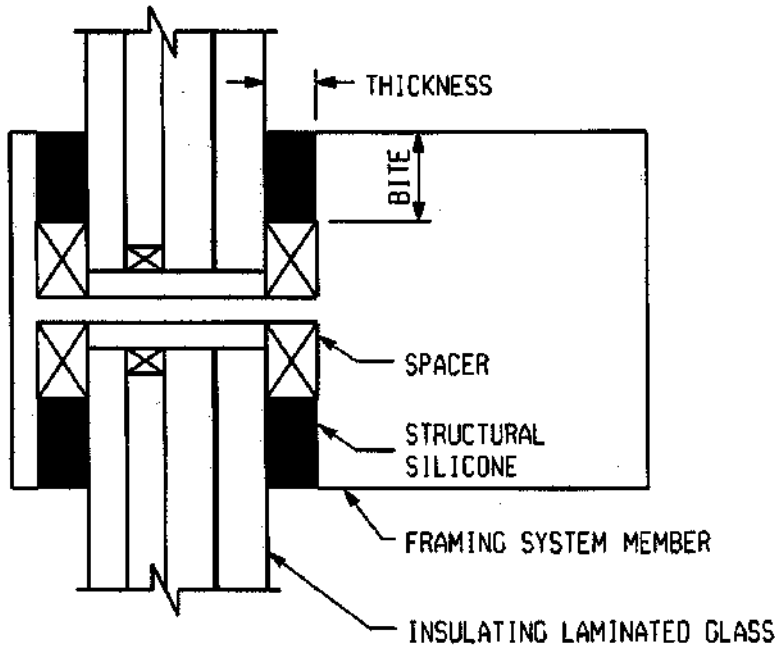

FIG. 6 Generic Missile Impact or Bomb Blast Detail with Insulating Laminated Glass

shop fabrication. Four-side structural sealant glazed systems are typically glazed in shop whereas two-side structural sealant glazed systems can be glazed either in shop or at the construction site. Shop glazing is preferential to construction site glazing. Film laminates, due to the nature of the application, are more often glazed at the building or construction site. Residential windows are typically glazed in the shop.

8.3 *Sealant Curing Considerations*—A single-component silicone sealant must be exposed to the atmosphere to cure

properly. Whether installed in the shop or at the construction site, various factors such as application temperature, relative humidity level, and liquid moisture will affect how the sealant cures and whether it will develop appropriate adhesion. Deep joints will take a longer period of time to cure. To aid sealant curing, sealant may be installed in successive layers allowing the sealant to cure between applications. Two component

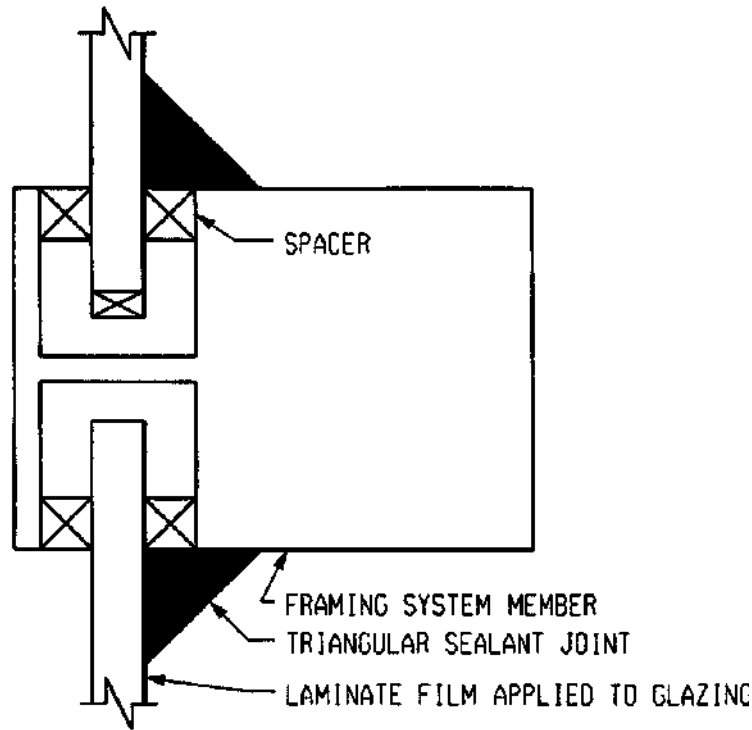

FIG. 7 Generic Retrofit Impact Resistant Detail with Monolithic Glass and Laminate

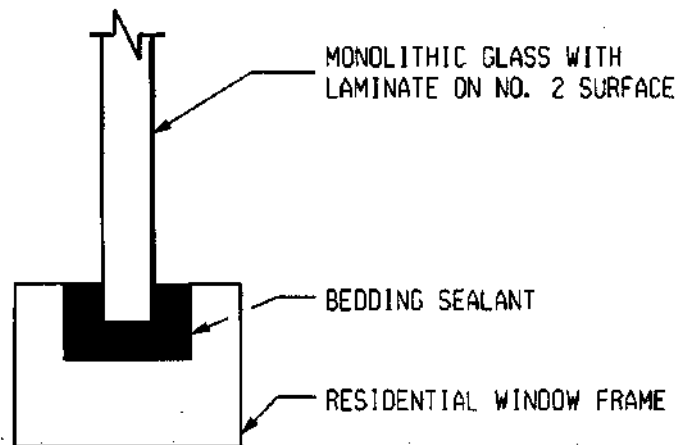

FIG. 8 Generic Residential Impact Resistance Detail

silicone sealants also have special consideration relating to cure that should be reviewed with the sealant manufacturer prior to use.

8.4 *Quality Assurance*—Sealant adhesion and performance is dependent on an appropriate quality control program. Accessibility to the sealant joint whether glazed at the construction site or in shop, will affect the quality of the installation and whether an appropriate quality control program can be properly implemented. Guide C 1401 reviews the components of a successful quality control program for the application of one and two component silicone sealants.

8.5 *Glazing System Design*—Understanding the weather-proofing design of a protective glazing system is important for

the system to perform properly. Many glazing systems are designed as pressure equalized systems whereas others are designed as internal drainage or primary seal systems. These systems are described in Guide C 1401. The sealant has a different role in each system. Some glazing systems are designed to internally manage water flow and weep holes are important to their proper performance. Using quality sealants for the internal framing seals of a window or curtain wall system is crucial for proper long-term water management.

8.6 *Reglazing*—Maintenance of a protective glazing system requires a procedure to inspect and reglaze where necessary. Guides C 1401 and C 1394 describe procedures to evaluate structurally glazed systems. The procedures outlined in Guide



C 1394 can be used to evaluate a protective glazed system. Each window or curtain wall manufacturer should provide written maintenance, evaluation, and repair procedures for their respective protective glazing system. Systems must be able to be reglazed in their original design.

9. Keywords

9.1 blast protection; impact glazing; protective glazing; silicone sealant; structural sealant

ASTM International takes no position respecting the validity of any patent rights asserted in connection with any item mentioned in this standard. Users of this standard are expressly advised that determination of the validity of any such patent rights, and the risk of infringement of such rights, are entirely their own responsibility.

This standard is subject to revision at any time by the responsible technical committee and must be reviewed every five years and if not revised, either reapproved or withdrawn. Your comments are invited either for revision of this standard or for additional standards and should be addressed to ASTM International Headquarters. Your comments will receive careful consideration at a meeting of the responsible technical committee, which you may attend. If you feel that your comments have not received a fair hearing you should make your views known to the ASTM Committee on Standards, at the address shown below.

This standard is copyrighted by ASTM International, 100 Barr Harbor Drive, PO Box C700, West Conshohocken, PA 19428-2959, United States. Individual reprints (single or multiple copies) of this standard may be obtained by contacting ASTM at the above address or at 610-832-9585 (phone), 610-832-9555 (fax), or service@astm.org (e-mail); or through the ASTM website (www.astm.org).