



Government
of Canada

Gouvernement
du Canada

Canadian General
Standards Board

Office des normes
générales du Canada

CAN/CGSB-12.1-2017

Supersedes CAN/CGSB-12.1-M90

National Standard of Canada

Safety glazing

Canadian General Standards Board **CGSB**



Standards Council of Canada
Conseil canadien des normes

Canada

Experience and excellence
Expérience et excellence



download from <https://elitesafetyglass.com>

The CANADIAN GENERAL STANDARDS BOARD (CGSB), under whose auspices this standard has been developed, is a government agency within Public Services and Procurement Canada. CGSB is engaged in the production of voluntary standards in a wide range of subject areas through the media of standards committees and the consensus process. The standards committees are composed of representatives of relevant interests including producers, consumers and other users, retailers, governments, educational institutions, technical, professional and trade societies, and research and testing organizations. Any given standard is developed on the consensus of views expressed by such representatives.

CGSB has been accredited by the Standards Council of Canada as a national standards-development organization. The standards that it develops and offers as National Standards of Canada conform to the criteria and procedures established for this purpose by the Standards Council of Canada. In addition to standards it publishes as National Standards of Canada, CGSB produces standards to meet particular needs, in response to requests from a variety of sources in both the public and private sectors. Both CGSB standards and CGSB national standards are developed in conformance with the policies described in the CGSB Policy and Procedures Manual for the Development and Maintenance of Standards.

CGSB standards are subject to review and revision to ensure that they keep abreast of technological progress. CGSB will initiate the review of this standard within five years of the date of publication. Suggestions for their improvement, which are always welcome, should be brought to the notice of the standards committees concerned. Changes to standards are issued either as separate amendment sheets or in new editions of standards.

An up-to-date listing of CGSB standards, including details on latest issues and amendments, and ordering instructions, is found in the CGSB Catalogue at our Web site — www.tpsgc-pwgsc.gc.ca/ongc-cgsb/index-eng.html along with more information about CGSB products and services.

Although the intended primary application of this standard is stated in its Scope, it is important to note that it remains the responsibility of the users of the standard to judge its suitability for their particular purpose.

The testing and evaluation of a product against this standard may require the use of materials and/or equipment that could be hazardous. This document does not purport to address all the safety aspects associated with its use. Anyone using this standard has the responsibility to consult the appropriate authorities and to establish appropriate health and safety practices in conjunction with any applicable regulatory requirements prior to its use. CGSB neither assumes nor accepts any responsibility for any injury or damage that may occur during or as the result of tests, wherever performed.

Attention is drawn to the possibility that some of the elements of this Canadian standard may be the subject of patent rights. CGSB shall not be held responsible for identifying any or all such patent rights. Users of this standard are expressly advised that determination of the validity of any such patent rights is entirely their own responsibility.

Language

In this Standard, “shall” states a mandatory requirement, “should” expresses a recommendation and “may” is used to express an option or that which is permissible within the limits of this Standard. Notes accompanying clauses do not include requirements or alternative requirements; the purpose of a note accompanying a clause is to separate from the text explanatory or informative material. Annexes are designated normative (mandatory) or informative (non-mandatory) to define their application.

Further information on CGSB and its services and standards may be obtained from:

The Manager
Standards Division
Canadian General Standards Board
Gatineau, Canada
K1A 1G6

A National Standard of Canada is a standard developed by an SCC-accredited Standards Development Organization (SDO), and approved by the Standards Council of Canada (SCC), in accordance with SCC’s: *Requirements and Guidance-Accreditation for Standards Development Organizations, and Requirements and Guidance-Approval of National Standards of Canada Designation*. More information on National Standard requirements can be found at www.scc.ca.

An SCC-approved standard reflects the consensus of a number of experts whose collective interests provide, to the greatest practicable extent, a balance of representation of affected stakeholders. National Standards of Canada are intended to make a significant and timely contribution to the Canadian interest.

SCC is a Crown corporation within the portfolio of Industry Canada. With the goal of enhancing Canada’s economic competitiveness and social well-being, SCC leads and facilitates the development and use of national and international standards. SCC also coordinates Canadian participation in standards development, and identifies strategies to advance Canadian standardization efforts. Accreditation services are provided by SCC to various customers, including product certifiers, testing laboratories, and standards development organizations. A list of SCC programs and accredited bodies is publicly available at www.scc.ca.

Users should always obtain the latest edition of a National Standard of Canada from the standards development organization responsible for its publication, as these documents are subject to periodic review.

The responsibility for approving standards as NSCs rests with:

Standards Council of Canada
55 Metcalfe Street, Suite 600
Ottawa, Ontario K1P 6L5, CANADA

How to order **CGSB** Publications:

- by telephone — 819-956-0425 *or*
— 1-800-665-2472
- by fax — 819-956-5740
- by mail — CGSB Sales Centre
Gatineau, Canada
K1A 1G6
- in person — Place du Portage
Phase III, 6B1
11 Laurier Street
Gatineau, Quebec
- by email — ncr.cgsb-ongc@tpsgc-pwgsc.gc.ca
- on the Web — www.tpsgc-pwgsc.gc.ca/ongc-cgsb/index-eng.html

NATIONAL STANDARD OF CANADA

CAN/CGSB-12.1-2017

Supersedes CAN/CGSB-12.1-M90

Safety glazing

CETTE NORME NATIONALE DU CANADA EST DISPONIBLE EN VERSIONS
FRANÇAISE ET ANGLAISE.

ICS 81.040.20

Published February 2017 by the
Canadian General Standards Board
Gatineau, Canada K1A 1G6

© HER MAJESTY THE QUEEN IN RIGHT OF CANADA,
as represented by the Minister of Public Services and Procurement,
the Minister responsible for the Canadian General Standards Board (2017).

No part of this publication may be reproduced in any form without the prior permission of the publisher.

download from <https://elitesafetyglass.com>

CANADIAN GENERAL STANDARDS BOARD

Committee on Glass

(Voting membership at date of approval)

Chair

Webb, M. Insulating Glass Manufacturers Alliance (Producer)

General interest category

Flack, J. Consultant
Steel, K. Steel Consulting Services
Zaremba, T. Roetzel & Andress, LPA

Producer category

Botman, R. Glassopolis Specialty Glass
Fraser, E. PPG Flat Glass Canada Inc.
Harder, B. Ferguson Corporation
Liversidge, M. Precision Glass Services Inc.
Schimmelpenningh, J. Eastman Chemical Company
Wakefield, R. Trulite Canada

Regulator category

Chowhan, P. Health Canada
Fortin, M. National Research Council of Canada

User category

Brook, M. BVDA Facade Engineering Inc.
Panziera, S. Thinkform Architecture & Interiors
Redmond, T. Ontario Building Official Association
Sharp, G. Canadian Home Builders' Association
Shelbourn, K. Canadian Building Envelope Science & Technology

Secretary (non-voting)

Jimenez, J. Canadian General Standards Board

Acknowledgment is made for the translation of this National Standard of Canada by the Translation Bureau of Public Services and Procurement Canada.

Contents	Page
Introduction.....	iii
1 Scope	1
2 Normative references	1
3 Terms and definitions	3
4 Classification	5
4.1 Laminated glazings	5
4.2 Fully tempered glazings	5
4.3 Organic-coated glazings	5
4.4 Plastic glazings	5
4.5 Mirror glazings	5
5 General requirements	5
6 Detailed requirements	6
6.1 Specimen size classification.....	6
6.2 Specimens for impact tests	6
6.3 Specimens for thermal test.....	7
6.4 Specimens for weathering tests.....	7
6.5 Specimens for modulus and hardness tests.....	7
7 Packaging, packing, labelling and marking	8
7.1 Marking information.....	8
7.2 Application of the mark	9
7.3 Special application marking.....	9
8 Inspection	9
9 Sampling	9
10 Testing	10
10.1 Impact test	10
10.2 Centre punch fragmentation test.....	23
10.3 Thermal test for laminated and organic coated glazings.....	24
10.4 Weathering tests for laminated, organic coated and plastic glazings.....	25
Annex A (informative) Areas of human impact.....	31

Figures

Figure 1 – Impact test structure	11
Figure 2 – Impactor bag	11
Figure 3 – Impact test frame – Front view.....	12
Figure 4 – Detail of section A-A properly clamped test specimen (> 3 mm (1/8 in.)).....	13
Figure 5 – Detail of section A-A improperly clamped test specimen (>3 mm (1/8 in.))	13
Figure 6 – Impact test frame – Side view.....	14
Figure 7 – Impact test frame – Bent glazing – Front view.....	15
Figure 8 – Detail of section B-B.....	16
Figure 9 – Detail of section C-C.....	16
Figure 10 – Detail of section D-D	17
Figure 11 – Bent glass impact test frame (Exploded view).....	17
Figure 12 – Impact test frame – Bent glazing – Side view	18
Figure 13 – Impactor.....	20
Figure 14 – Centre punch fragmentation.....	24

Tables

Table 1 – Grouping of tests for different glazing materials	10
Table 2 – Applicable interpretation of results for shot bag impact.....	22
Table 3 – Accelerated weathering conditions	26
Table 4 – Accelerated weathering conditions – Indoor product use.....	29

Introduction

Past editions of CAN/CGSB-12.1 were specific to tempered and laminated safety glass. The objectives of the CGSB Committee on Glass with this 2017 edition were to

- a) clearly define safety glass and its product categories;
- b) align as much as possible with the American National Standard ANSI Z97.1, *Safety Glazing Materials Used in Buildings – Safety Performance Specifications and Methods of Test*;
- c) update the Standard to address technologies and products introduced into the market since 1990; and
- d) ensure that this Standard is applicable to Canadian building practices and compliant with the National Building Code of Canada.

To facilitate the above objectives, the CGSB Committee on Glass had representation from all the safety glazing product manufacturing sectors, representatives from the ANSI Z97.1 committee, as well as representation from other sectors to ensure the required Committee balance.

The scope, application and labelling requirements of CAN/CGSB-12.1 and ANSI Z97.1 have now been aligned, including product categories and tests.

Acknowledgment is extended to the members of the ANSI Z97.1 Committee for working so closely with the CGSB Committee on Glass. Their assistance in providing access to the ANSI Z97.1 standard and any background information needed was essential to the development of this Standard.

Safety glazing

1 Scope

This National Standard of Canada applies to glazing materials that have been subjected to the test methods described herein. Such test methods are intended to demonstrate minimum performance characteristics designed to reduce the likelihood of cutting and piercing injuries resulting when glazing materials used in areas of human impact (see Annex A) in building and architectural applications are broken by human impact.

This standard does not address the strength, durability, fire rated characteristics, appearance or methods of installation for glazing materials.

The following are not considered safety-glazing materials under this standard: monolithic annealed glass, monolithic heat-strengthened glass, monolithic chemically-strengthened glass, monolithic glass-ceramic and monolithic wired glass.

The testing and evaluation of a product against this standard may require the use of materials and/or equipment that could be hazardous. This document does not purport to address all the safety aspects associated with its use. Anyone using this standard has the responsibility to consult the appropriate authorities and to establish appropriate health and safety practices in conjunction with any applicable regulatory requirements prior to its use.

2 Normative references

The following normative documents contain provisions that, though referenced in this text, constitute provisions of this National Standard of Canada. The referenced documents may be obtained from the sources noted below.

NOTE The addresses provided below were valid at the date of publication of this standard.

An undated reference is to the latest edition or revision of the reference or document in question, unless otherwise specified by the authority applying this standard. A dated reference is to the specified revision or edition of the reference or document in question.

2.1 Canadian General Standards Board (CGSB)

CAN/CGSB-12.2 — *Flat, clear sheet glass*

CAN/CGSB-12.3 — *Flat, clear float glass.*

2.1.1 Source

The above may be obtained from the Canadian General Standards Board, Sales Centre, Gatineau, Canada K1A 1G6. Telephone 819-956-0425 or 1-800-665-2472. Fax 819-956-5740. E-mail ncr.cgsb-ongc@tpsgc-pwgsc.gc.ca. Web site www.tpsgc-pwgsc.gc.ca/ongc-cgsb/index-eng.html.

2.2 American National Standards Institute (ANSI)

ANSI Z97.1 — *Safety Glazing Materials Used in Buildings — Safety Performance Specifications and Methods of Test.*

2.2.1 Source

The above may be obtained from the Copyright Accredited Standards Committee (ASC) Z97; 800 SW Jackson St. Suite 1500, Topeka, KS 66612-1200, telephone (785) 271-0208, fax (785) 271-0166, Web site www.ansiz97.com.

2.3 ASTM International

C1036 — *Standard Specification for Flat Glass*

C1048 — *Standard Specification for Heat-Strengthened and Fully Tempered Flat Glass*

C1172 — *Standard Specification for Laminated Architectural Flat Glass*

C1349 — *Standard Specification for Architectural Flat Glass Clad Polycarbonate*

C1464 — *Standard Specification for Bent Glass*

D785 — *Standard Test Method for Rockwell Hardness of Plastics and Electrical Insulating Materials*

D790 — *Standard Test Methods for Flexural Properties of Unreinforced and Reinforced Plastics and Electrical Insulating Materials*

D1003 — *Standard Test Method for Haze and Luminous Transmittance of Transparent Plastics*

D1435 — *Standard Practice for Outdoor Weathering of Plastics*

D2240 — *Standard Test Method for Rubber Property – Durometer Hardness*

D2244 — *Standard Practice for Calculation of Color Tolerances and Color Differences from Instrumentally Measured Color Coordinates*

D2565 — *Standard Practice for Xenon-Arc Exposure of Plastics Intended for Outdoor Applications*

D6110 — *Standard Test Method for Determining the Charpy Impact Resistance of Notched Specimens of Plastics*

E308 — *Standard Practice for Computing the Colors of Objects by Using the CIE System*

E313 — *Standard Practice for Calculating Yellowness and Whiteness Indices from Instrumentally Measured Color Coordinates*

G155 — *Standard Practice for Operating Xenon Arc Light Apparatus for Exposure of Non Metallic Materials.*

2.3.1 Source

The above may be obtained from ASTM International, 100 Barr Harbor Drive, West Conshohocken, PA 19428-2959, U.S.A., telephone 610-832-9585, fax 610-832-9555, Web site www.astm.org, or from IHS Markit, 200-1331 MacLeod Trail SE, Calgary, Alberta T2G 0K3, telephone 613-237-4250 or 1-800-267-8220, fax 613-237-4251, Web site www.global.ihs.com.

2.4 International Organization for Standardization (ISO)

ISO 4892-2 — *Plastics — Methods of exposure to laboratory light sources — Part 2: Xenon-arc lamps.*

2.4.1 Source

The above may be obtained from IHS Markit, 200-1331 MacLeod Trail SE, Calgary, Alberta T2G 0K3, telephone 613-237-4250 or 1-800-267-8220, fax 613-237-4251, Web site www.global.ihs.com.

2.5 Japanese Industrial Standards (JIS)

JIS R3205 – *Laminated glass*.

2.5.1 Source

The above may be obtained from the Japanese Industries Standards, 1-3-1 Kasumigaseki, Chiyoda-ku, Tokyo 100-8901, JAPAN.

3 Terms and definitions

For the purposes of this National Standard of Canada, the following terms and definitions apply.

3.1

asymmetric material

glazing in which component layers of its construction makeup are different in thickness, kind, type or pattern texture about its interlayer or film and/or central plane surface.

3.2

bent glass

flat glass that has been shaped while hot into a form that has curved surfaces.

3.3

bubble

visible gas pocket in the interlayer material or in the plastic glazing sheet material, or between the interlayer and another layer of glass or plastic glazing sheet material.

3.4

cracking

visible breaking, splitting or fissuring, either partially or completely through the thickness of an individual layer of material.

3.5

crack-free particle

portion of a broken test specimen that is determined by identifying the smallest possible perimeter around all points in the portion of the broken test specimen, always passing along un-separated cracks or exposed surfaces.

3.6

crazing

visible breaking, splitting or fissuring of a material, typically patterned with a network of fine lines that do not penetrate through the thickness of an individual layer of material.

3.7

delamination

condition in which one of the glass or plastic glazing sheet material layers loses its bond to an interlayer and separates physically.

3.8

discoloration

noticeable chemical or process induced colour deviation in the appearance of a material that is visible to the unaided or corrected eye.

3.9

fully tempered glass

glass of any shape that has been subjected to a thermal treatment process characterized by uniform heating followed by rapid uniform cooling to produce compressively stressed surface layers. See ASTM C1048 for additional requirement information.

3.10

laminated glazing

manufactured assembly consisting of at least one sheet of glass or glass-ceramic bonded to at least one other sheet of glass, glass-ceramic or plastic glazing material with an organic interlayer.

NOTE When broken, numerous cracks appear, but glass fragments tend to adhere to the interlayer. See ASTM C1172 for additional information.

3.10.1

2-ply glass laminates

laminated glazing consisting of two sheets of glass bonded together with an interlayer.

3.10.2

multi-ply glass laminates

laminated glazing consisting of more than two layers of glass and/or plastic glazing sheet material bonded together by interlayers, where both of the outer surfaces are glass.

3.10.3

glass/plastic laminates

laminated glazing consisting of one or more layers of glass and one or more layers of plastic glazing sheet material bonded together with one or more interlayer(s) in which the plastic surface faces inward or toward an insulating cavity, when the glazing is installed in a structure.

3.10.4

mirror glazing

architectural glazing materials whose intended use is based on their reflective quality. These materials are composed of a reflective surface and may have a substrate of glass, or plastic.

3.10.5

organic coated glass

assembly consisting of a sheet of glass covered on one or both surfaces with either: (1) an adhesive-applied organic film or sheeting, or (2) an applied coating. When broken numerous cracks appear, but the glass fragments tend to adhere to the applied organic material.

3.10.6

plastic glazing material

single sheet of synthetic plastic material, a combination of two or more such sheets laminated together, or a combination of plastic material and reinforcement material in the form of fibres or flakes. This material contains, as an essential ingredient, an organic substance of large molecular weight; is solid in its finished state; and, at some stage in its manufacture or in its processing into finished articles, can be shaped by flow. See ASTM C1349 for additional information.

3.10.7

safety glazing materials

glazing materials so constructed, treated, or combined with other materials that, if broken by human contact, the likelihood of cutting or piercing injuries that might result from such contact is reduced.

4 Classification

4.1 Laminated glazings

Glazing assemblies consisting of one or more sheets of glazings and/or plastic glazing material bonded together with one or more organic interlayers. Laminated glazings can include 2-ply laminates, multi-ply laminates and glass/plastic laminates. When broken, numerous cracks may appear, but glass fragments may adhere to the interlayer(s).

NOTE For additional information, see ASTM C1172.

4.2 Fully tempered glazings

Glass lites that have been thermally treated in a manufacturing process of uniform heating followed by rapid uniform cooling that produces compressively stressed surface layers in the glass. When broken, the entire lite cracks immediately into very small, granular pieces. Fully tempered glass is also known as toughened glass.

NOTE For additional information, see ASTM C1048.

4.3 Organic-coated glazings

Glazing assemblies consisting of a lite of glass covered on one or both surfaces with either: 1) an adhesive-applied organic film or sheeting, or 2) an applied organic coating. When broken, numerous cracks appear, but the glass fragments may adhere to the organic coating. Examples of glazings that can be organically coated include wire glass, glass-ceramic, annealed glass, fully tempered glass, chemically strengthened glass, heat strengthened glass and mirror glazings.

4.4 Plastic glazings

A single sheet of synthetic plastic material, a combination of two or more such sheets laminated together, or a combination of plastic material and reinforcement material in the form of fibres or flakes. This material contains as an essential ingredient an organic substance of large molecular weight; is solid in its finished state; and, at some stage in its manufacture or in its processing into finished articles, can be shaped by flow.

NOTE For additional information, see ASTM C1349.

4.5 Mirror glazings

Glazing materials are used architecturally for their reflective qualities. Mirror glazings have a reflective surface and a substrate of glass or plastic.

NOTE For additional information, see ASTM C1503.

5 General requirements

5.1 Tests shall be applied to specimens as shipped by the manufacturer and shall be representative of commercial production, except that any protective masking material shall be removed prior to test.

5.2 The thickness of the specimens to be tested shall be measured and recorded along with the nominal thickness. No manufacturer shall mark or advertise as passing the tests described in this standard, any product of different nominal thickness than that of the specimens passing the tests.

6 Detailed requirements

6.1 Specimen size classification

A description of impact to be tested as required for size classification are set forth below.

6.1.1 Unlimited size (U)

863 mm x 1930 mm, ± 3 mm (34 in. x 76 in., $\pm 1/8$ in.).

6.1.2 Limited size (L)

Appropriate to manufacturer, largest size commercially produced by the manufacturer less than 863 mm x 1930 mm, ± 3 mm (34 in. x 76 in., $\pm 1/8$ in.). Minimum specimen size: 406 mm x 762 mm, ± 3 mm (16 in. x 30 in., $\pm 1/8$ in.).

No manufacturer submitting specimens that are in the Limited Size Classification shall mark or advertise as passing the tests described in this standard, any product with either dimension greater than those of the specimens that have passed the tests.

6.2 Specimens for impact tests

6.2.1 Safety glazing material

a) Any applications

For impact test (see 10.1) of any safety glazing material, four specimens, each of the thickness and size described in 5.2.1 and 6.1 respectively, are required. If the test specimens are of an asymmetric material, two shall be impacted from each side.

NOTE Testing of alternate shapes and sizes other than those specified in 6.2 does not qualify the product for unlimited use.

b) Indoor applications

For impact test after aging (see 10.4.3.3) of safety glazing materials used in indoor applications, four specimens, each of the thickness and size described in 5.2.1 and 7.1 respectively, are required. If the test specimens are of an asymmetric material two shall be impacted from each side.

6.2.2 Mirror glazing with organic adhesive backing material

For mirror glazing using either reinforced or non-reinforced organic adhesive backing material, four specimens each with the backing material applied, of the thickness and size described in 10.2 and 10.3 respectively, are required. The specimens shall be impacted only on the non-reinforced side and with no other material applied.

6.2.3 Bent glass

Bent glass test methods shall be the same as for flat sample testing except as referenced in the text and figures of this standard (See Figures 7, 8, 9, 10, 11 and 12). For unlimited size (U) classification of bent glass, 864 mm x 1930 mm (34 in. x 76 in.) specimens with a simple arc-shaped bend of 1016 mm (40 in.) shall be tested. Interpretation of results shall be the same.

NOTE 1 See ASTM C1464 for additional information.

NOTE 2 Where project specific requirements or limitations in production exist, other shapes and sizes may be tested.

6.3 Specimens for thermal test

For thermal test (see 10.3) three specimens, each 310 mm x 310 mm (12 in. x 12 in.), representative of commercial production and of identical manufacture and nominal thickness as submitted for impact testing (see 6.2), are required.

6.4 Specimens for weathering tests

For weathering tests (see 10.4), specimens as described in 6.4.1 and 6.4.2, representative of commercial production and of the thinnest construction for which qualification is desired, are required. Specimens constructed of laminated glass, organic-coated glazings or plastics, that have decorative or other functional materials inserted or embedded within the glazing material, shall not need to undergo weathering and subsequent testing if all of the following criteria are met:

- a) The interlayer, organic coating or plastic material encapsulates the decorative or otherwise functional material
- b) The interlayer, organic coating or plastic is deemed to comply with 10.4.
- c) The thickness of the interlayer, organic coating or plastic on each side of the insert or embedded material is at least the minimum thickness as qualified in 10.4.

The use of an insert or embedded material does not preclude the requirements for impact testing.

6.4.1 Plastic glazing material

One unbacked panel, a minimum of 152 mm x 152 mm (6 in. x 6 in.), shall be exposed. One additional unbacked panel, a minimum of 152 mm x 152 mm (6 in. x 6 in.), shall be kept in darkness and used as a control.

A minimum of five specimens, each 127 mm x 127 mm (1/2 in. x 5 in.), is necessary for the Charpy Impact Test (ASTM D6110). Alternate panel sizes may be used provided that enough material exists to cut a total of five specimens after exposure. Edges shall be trimmed from exposed panels prior to cutting specimens to minimize edge effects. For materials suspected of being anisotropic, the direction of one axis shall be marked on each panel, and all specimens shall be cut in the same direction.

6.4.2 Laminated glazing and organic coated glazing

Six specimens, each a minimum of 50 mm x 152 mm (2 in. x 6 in.) shall be prepared. Three specimens shall be exposed and three shall be kept in darkness and used as controls. Optical measurements for visible light transmittance, yellowness, haze and colour may be taken on an unexposed sample designated for exposure to serve as the unexposed control values.

6.4.3 Mirror glazing

Mirror glazing shall not be used for external glazing without passing all requirements for organic coated glass.

6.5 Specimens for modulus and hardness tests

6.5.1 Specimens for flexural modulus

The specimen dimensions are dependent on the thickness of the material and the span distance capabilities of the testing machine. The dimensions shall meet the requirements of ASTM D790 for flatwise tests.

6.5.2 Specimens for Rockwell hardness

The specimens shall be at least 25 mm (1 in.) square and at least 6 mm (1/4 in.) thick. Materials less than 6 mm (1/4 in.) thick may be stacked provided that the precautions noted in ASTM D785 are met.

NOTE For common plastic glazing thickness and common testing machine capabilities, specimens 12.7 mm (1/2 in.) wide and 127 mm (5 in.) long can meet the requirements. Decreased width and/or increased length may be needed in some cases to meet the span to depth ratio, span to width ratio and span to length requirements of the standard.

7 Packaging, packing, labelling and marking

After having successfully met the requirements of this standard, like products of the same nominal thickness produced in the same manner as the specimens which conform, shall be legibly and permanently marked.

7.1 Marking information

7.1.1 Content of the mark

The mark shall contain the following information:

- a) Supplier's name, distinctive mark or designation.
- b) Standard designation: CAN/CGSB-12.1-2017.
- c) Classification of test size (L or U) and drop height class (A or B). Plastic glazing does not require drop height.
- d) Place of fabrication (if fabricator has more than one location fabricating the product).

NOTE Additional details and information, such as thickness and date of manufacture, are permitted.

7.1.2 Example of the mark

Individual layout of the mark may vary based on the manufacturer and the product, and are deemed acceptable upon meeting the requirements in 8.1.

Basic

Glazing company A

CAN/CGSB-12.1-2017 LA INT

Plant ID (if more than one location)

Basic with some optional information

Glazing company B

Laminated (optional)

CAN/CGSB-12.1-2017 LA INT

Plant ID (if more than one location)

101014 (Date code optional)

7.2 Application of the mark

The appropriate party using the following guidelines shall apply the permanent mark:

- a) Laminated glass stock sheets (i.e., size produced by the manufacturer) shall be marked by the manufacturer of the stock sheet.
- b) All glazing products including cut size laminates, fully tempered glass, and organic coated glazing shall be marked by the company producing the finished cut to size glass product.
- c) The fabricator or manufacturer shall mark plastic glazing materials.
- d) The installer of the safety film shall mark field-applied organic coatings (films).

7.3 Special application marking

Certain types of glazing material shall also be marked with additional information as appropriate.

7.3.1 Safety glazing materials used in indoor applications only

After having successfully passed the appropriate tests (see 10.4.3), like products and materials produced in the same manner as specimens submitted for testing shall be legibly and permanently marked with the words - "Indoor Use Only".

7.3.2 Organic coated glass only

Organic coated glazing materials shall be legibly and permanently marked with the words "Glaze This Side In" to indicate to the installer, inspector, or user which side of the organic coated glass should be exposed to the elements if there is a specific side that should be exposed.

8 Inspection

Upon inspection, product marked in compliance with this standard shall have passed the requirements of section 10.

9 Sampling

Sampling shall be as required by the inspection authority.

10 Testing

Table 1 – Grouping of tests for different glazing materials

Test	Glazing materials ^a			
	Laminated glazings	Fully tempered glass	Organic coated glazings	Plastic glazing
Impact (see 10.1)	X	X	X	X
Centre punch fragmentation (see 10.2)		X ^b		
Thermal (see 10.3)	X		X ^c	
Weathering ^d (see 10.4)	X		X ^e	X
Indoor aging (see 10.4.3)	X		X	X
Hardness (see 6.5 and 10.1.4 c)				X ^f
Modulus (see 6.5 and 10.1.4 c)				X ^f

^a Bent and mirror glazing shall be tested in accordance with requirements of the base-glazing product (see 6.2).
^b Centre Punch Fragmentation test is used to evaluate the fracture pattern of fully tempered glass specimens that do not break during impact test of 10.1.
^c Thermal test only applies to organic coated glazings when organic coated glazings are used in the building envelope.
^d Weathering tests on laminated and organic coated glasses shall be performed on the thinnest construction of all components with clear glass, clear plastics and clear interlayers.
^e Mirror glazing shall be tested in accordance with 10.4.3.
^f Only required if breakage occurs under impact.

10.1 Impact test

Required specimens shall be tested as submitted except that any protective masking or protective material shall be removed prior to the test. Any applied coating integral to the specimens shall not be removed. The specimens shall be conditioned to a uniform test temperature between 18°C and 29°C (65°F and 85°F) for at least 4 h with separation to permit free air circulation.

10.1.1 Apparatus

The test apparatus shall consist of a test frame and an impactor system. The test frame consists of a main frame mounted on two base beams with stiffening members and a sub-frame, in which the specimen is held. The impactor system consists of the impactor, traction, release, and suspension devices.

10.1.1.1 Main frame

The main frame shall be constructed to minimize movement, deflection, twisting or racking of its members during testing. For this purpose, the structural framing members shall be steel angles 76 mm x 127 mm x 6 mm (3 in. x 5 in. x 1/4 in.) or other sections and materials of equal or greater rigidity. The main frame shall be welded or securely bolted at the corners and braced as shown in figures 1, 2 and 5.

The main frame is mounted to a rigid floor and/or wall. Horizontal members made of steel sections connect the main frame to a rigid wall. The base beams are connected to the main frame by diagonal members of steel sections (see figures 1, 2 and 5.). Attach the two base beams of the main frame to a concrete base or floor using bolts M16 or equivalent.

Internal dimensions of main frame (figure 2) shall be: Internal width: 835 mm ± 5 mm (33.25 in. ± 1/5 in.), Internal height: 1902 mm ± 5 mm (75.25 in. ± 1/5 in.)

The internal dimensions of the main frame shall be 28 mm (1.1 in.) less than unlimited-size (863 mm x 1930 mm [34 in. x 76 in.]) specimen dimensions.

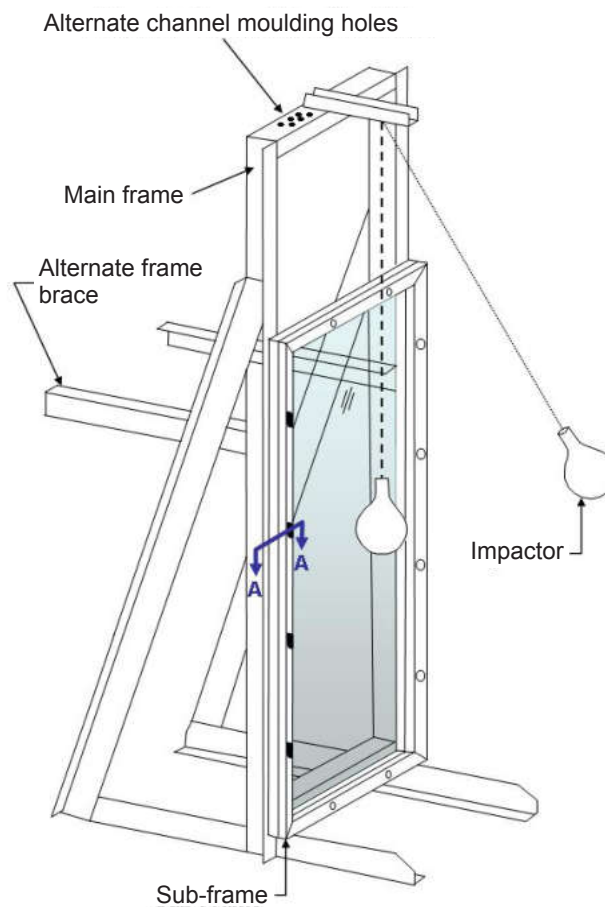

Figure 1 – Impact test structure

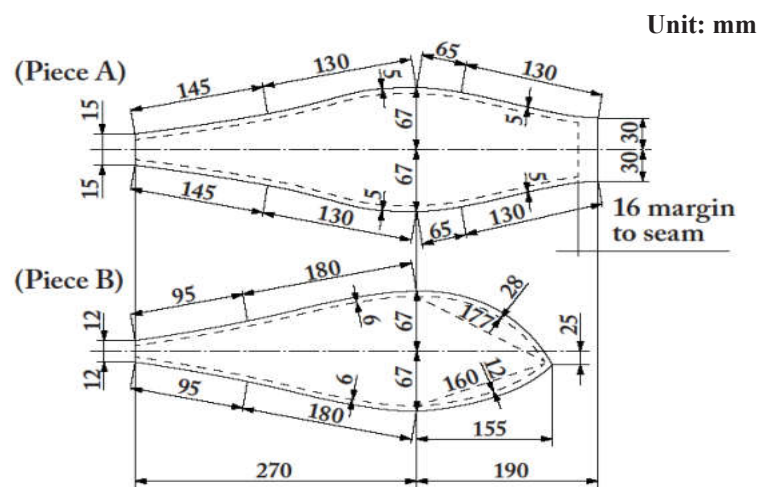

Figure 2 – Impactor bag

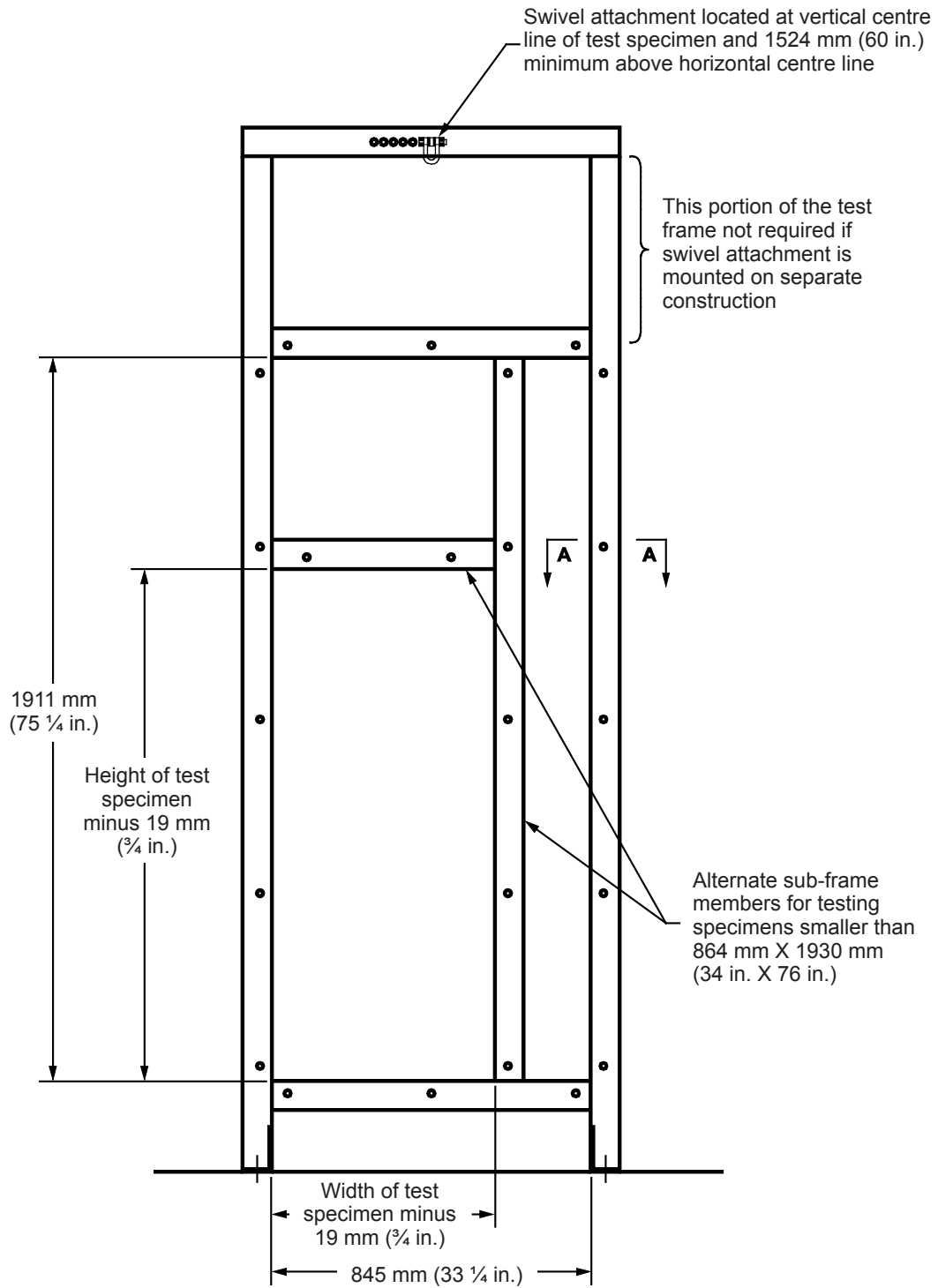

Figure 3 – Impact test frame – Front view

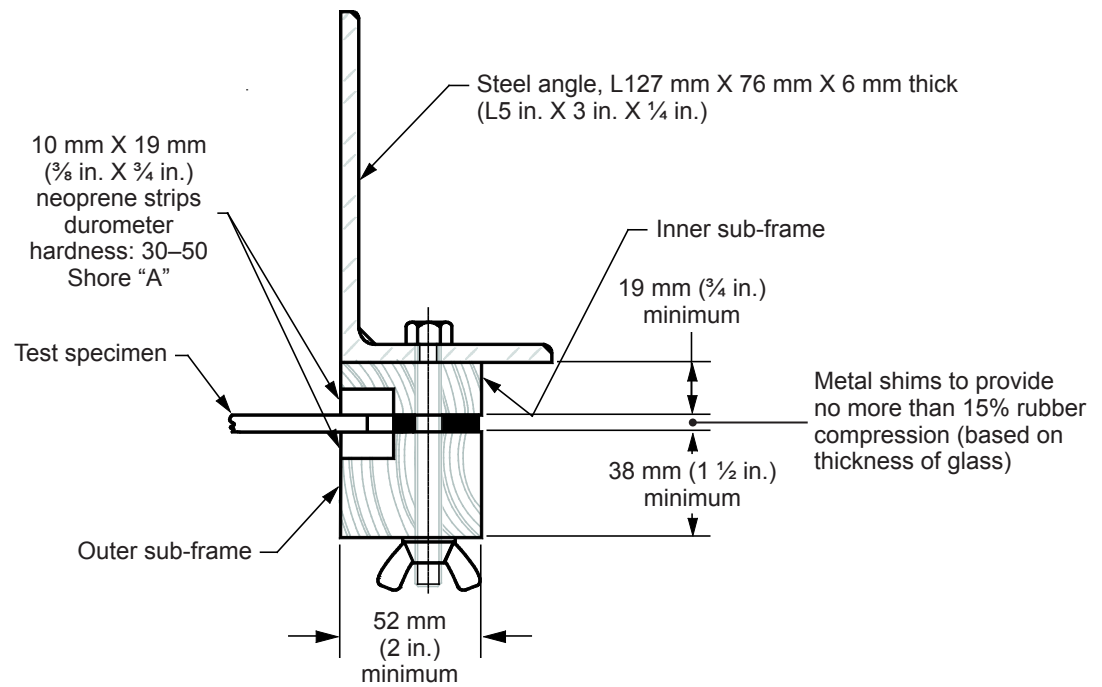

Figure 4 — Detail of section A-A properly clamped test specimen (> 3 mm (1/8 in.))

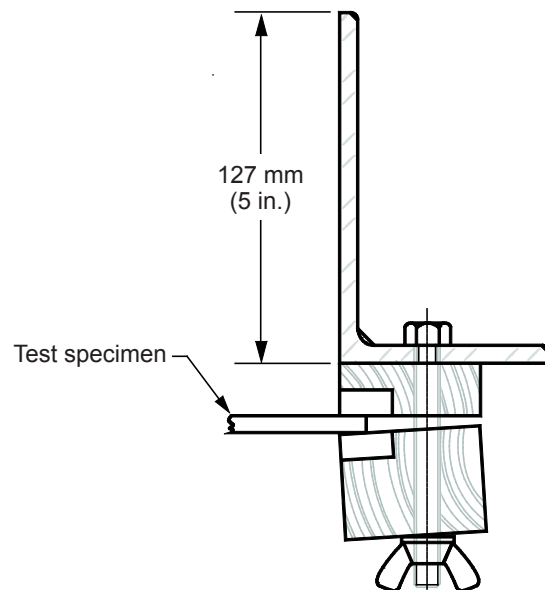

Figure 5 — Detail of section A-A improperly clamped test specimen (>3 mm (1/8 in.))

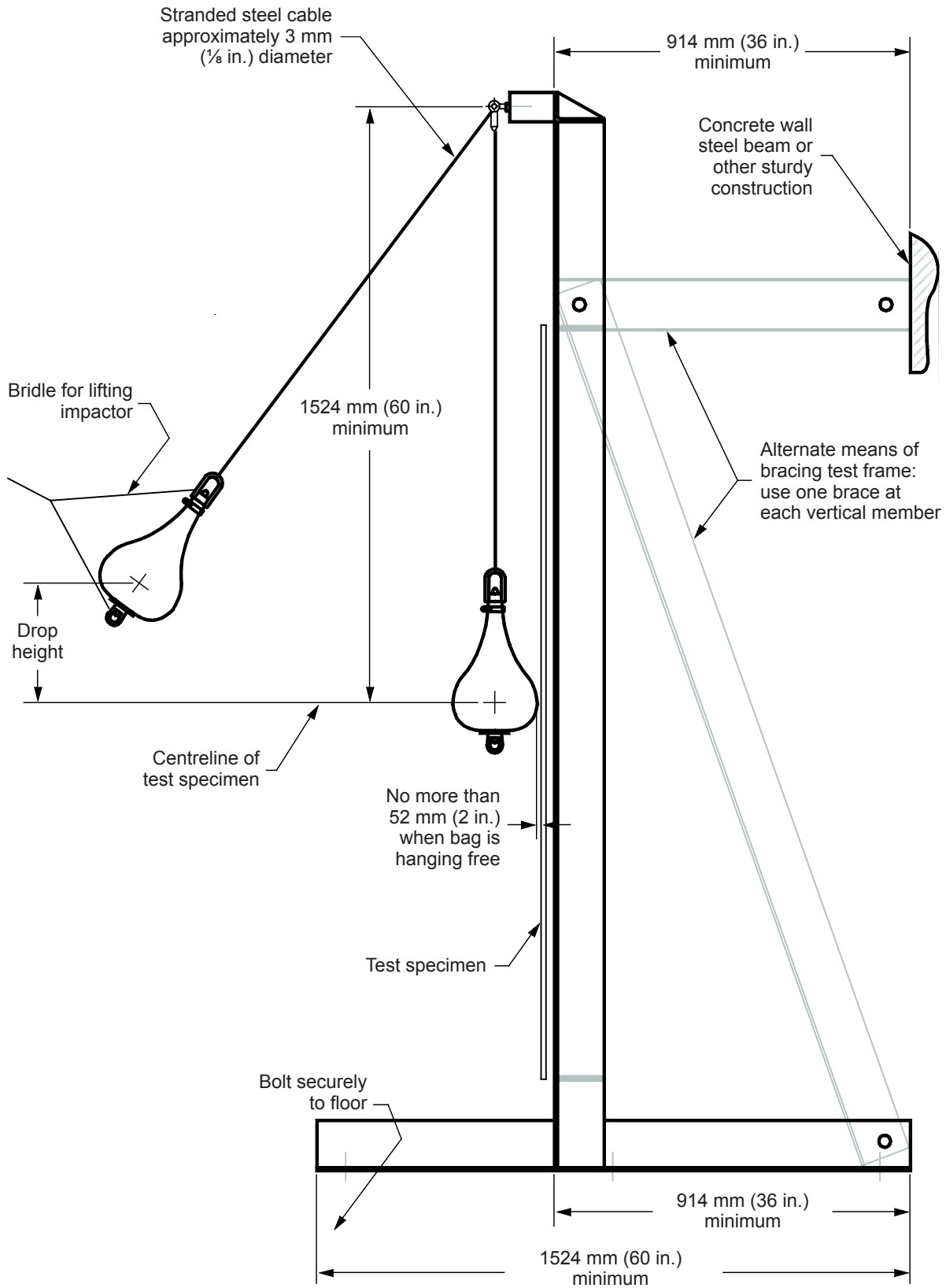

Figure 6 — Impact test frame — Side view

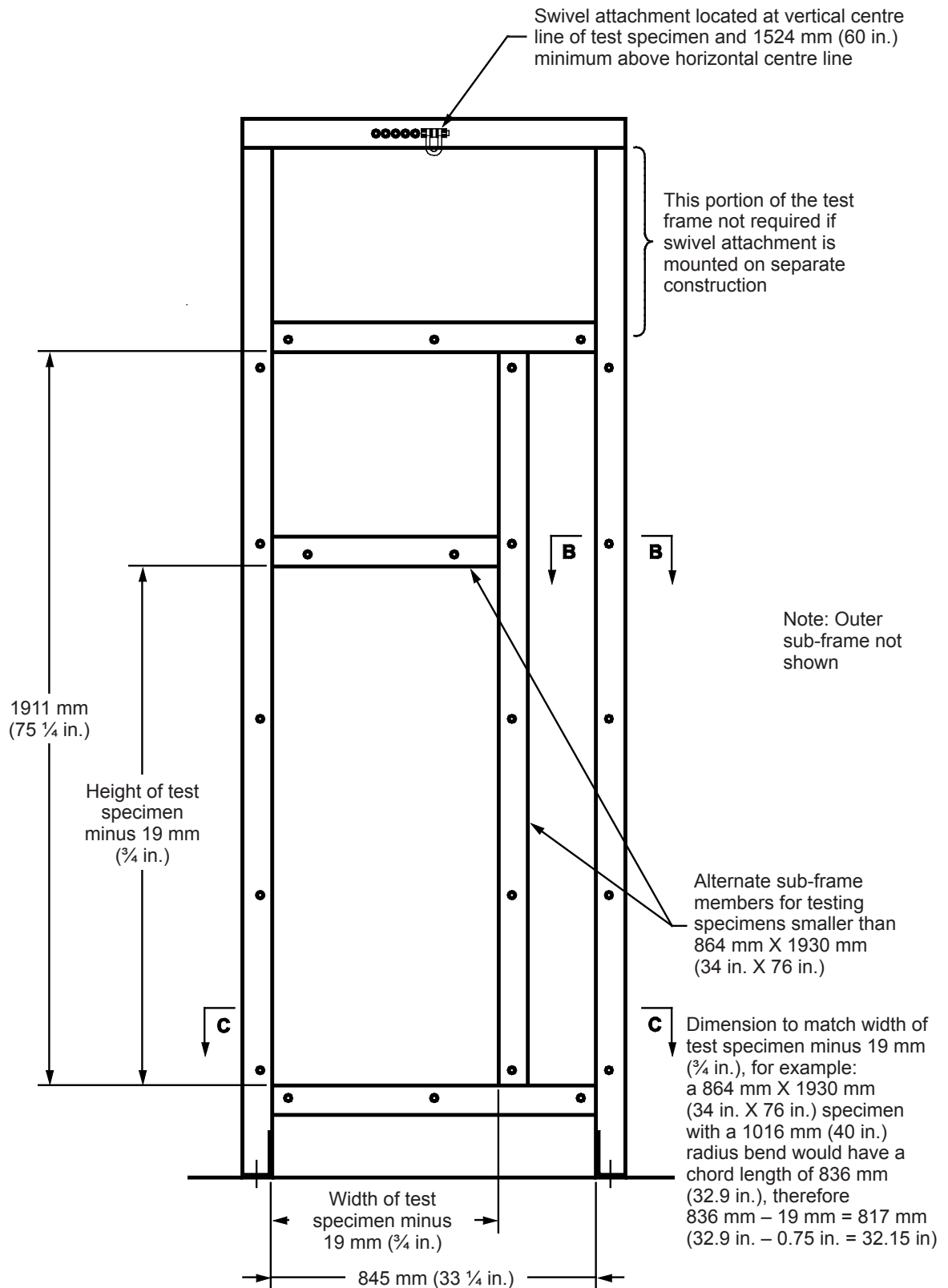

Figure 7 – Impact test frame – Bent glazing – Front view

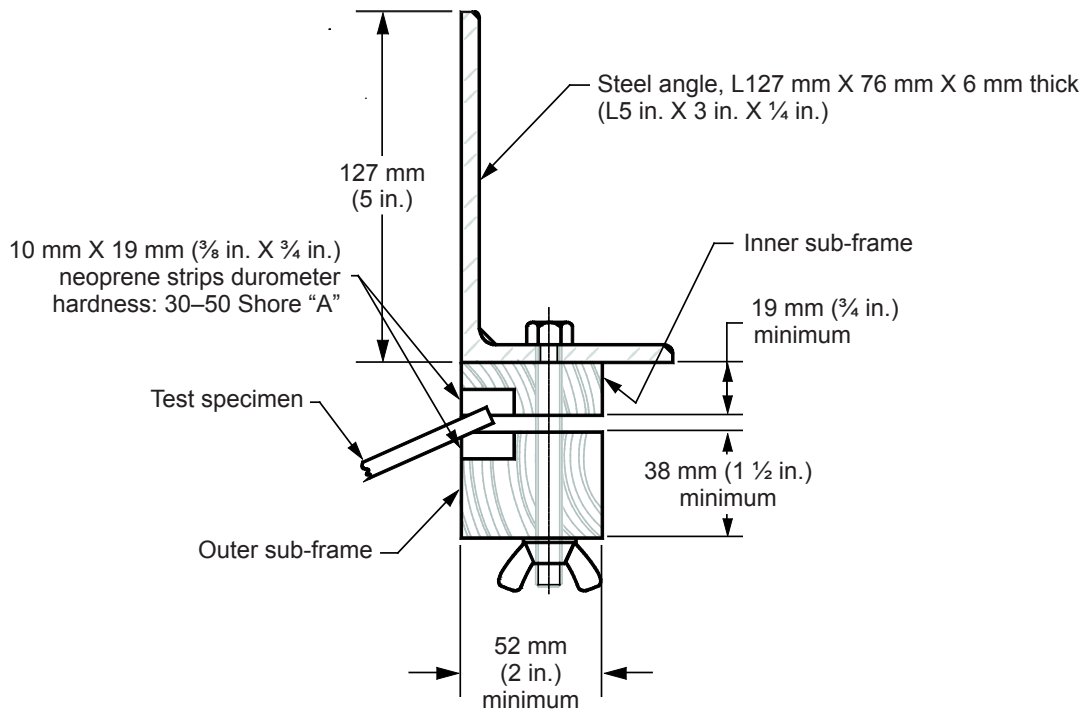

Figure 8 – Detail of section B-B

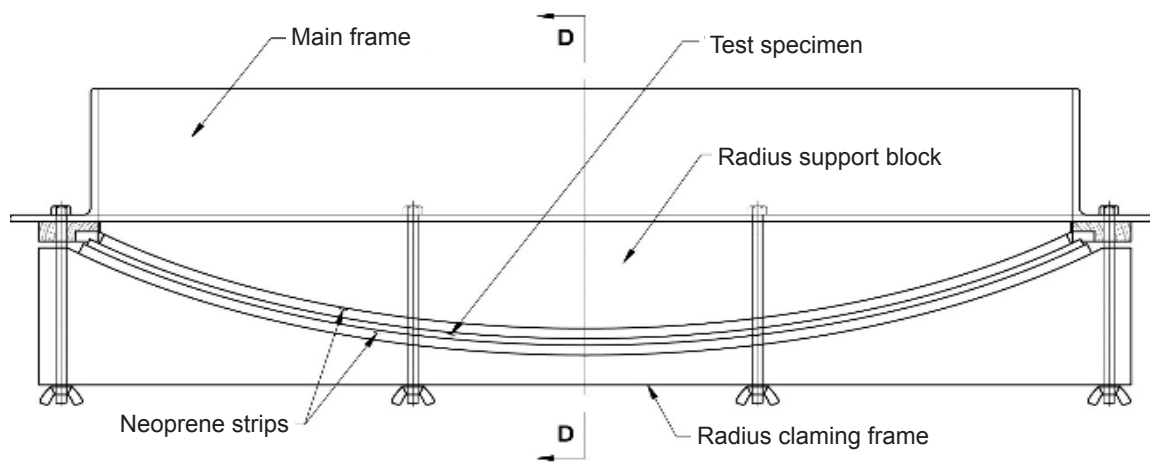

Figure 9 – Detail of section C-C

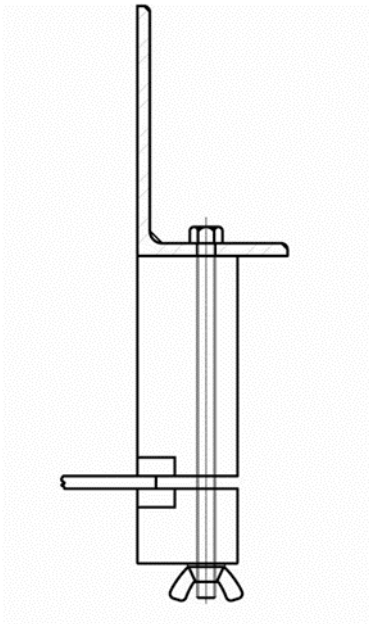

Figure 10 – Detail of section D-D

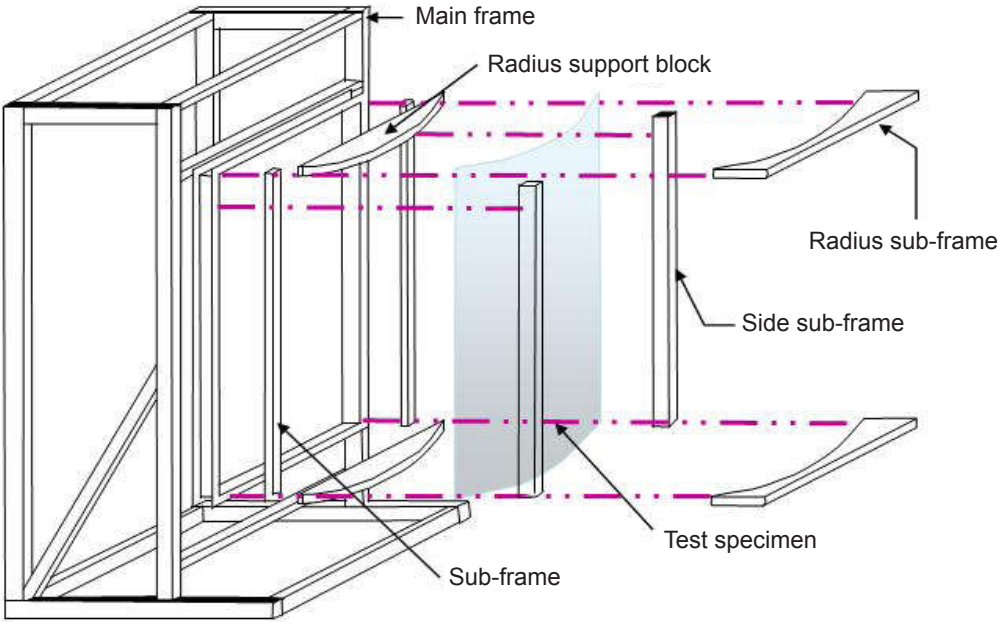

Figure 11 – Bent glass impact test frame (Exploded view)

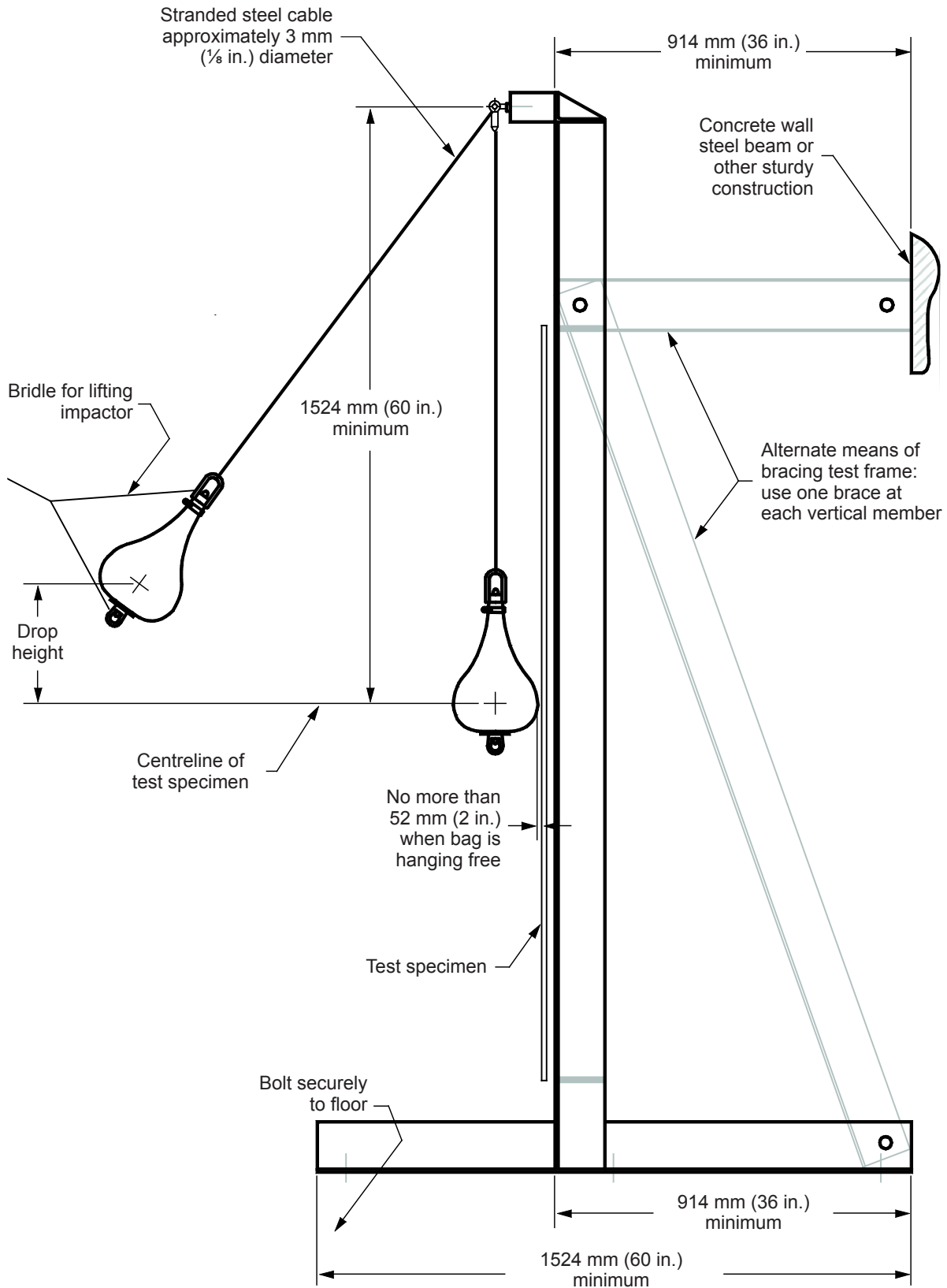

Figure 12 – Impact test frame – Bent glazing – Side view

10.1.1.2 Sub-frame (Test specimen mounting frame) (See Figures 2 and 3)

The sub-frame for securing the specimens on all four edges consists of two parts made from wood or other material, which is hard enough to withstand the pressure exerted by the clamping forces. Each part shall be provided with a groove or rebate in which a strip of elastomeric rubber is laid; the specimen shall only contact the elastomeric rubber strips.

The inner sub-frame (see Figures 4 and 5), which is in contact with the specimen, is 50 mm x 19 mm (2 in. x 3/4 in.) minimum. The outer part of the sub-frame holds the specimen and is 50 mm x 38 mm (2 in. x 1.5 in.) minimum.

The sub-frame is fixed to the main frame by at least twelve bolts (M10 bolts, scissors clamps or equivalent). These shall be fixed at the points marked on Figure 2 and Figure 3, with no fewer than two on any edge and spaced no more than 450 mm (18 in.) apart.

To provide and limit elastomeric rubber compression and avoid sub-frame distortion, non-compressible shims appropriate to glazing thickness shall be used to separate the inner and outer parts of the sub-frame (see Figure 4).

The elastomeric rubber strip, the only element of the sub-frame that the test specimen shall come into contact with, shall be 20 mm (4/5 in.) wide by 10 mm (2/5 in.) thick and have a Shore-A hardness of 40 ± 10 (see ASTM D2240).

NOTE Modifications that clearly do not alter the function or performance of the mainframe or sub-frame are acceptable. Any reasonable means may be used to secure the sub-frame to the main frame provided the mounting is secure and the pressure on the glazing specimen in the sub-frame is controlled.

10.1.1.3 Impactor

The impactor shall consist of the leather bag described in Figure 13, a commercial punching bag with its bladder left in place, or any other leather bag of nominally identical shape and size. The bag shall be filled with lead shot of 2.4 mm \pm 0.1 mm diameter (nominal USA No. 7 1/2 or European No. 7 lead shot) and taped. After filling with lead shot, the top shall be either pulled over the metal sleeve and tied with a cord; or twisted around the threaded eyebolt shaft and tied below the metal sleeve, or both. To reduce bag damage during testing, the exterior of the leather bag surface shall be completely covered with glass filament reinforced pressure sensitive polyester adhesive tape¹, 12 mm to 15 mm (1/2 in. to 3/5 in.) in width and 0.15 mm (0.006 in.) thick. Tape the entire bag, using three (3) rolls or 165 m (180 yards) total length, and taping in a diagonal-overlapping manner. Tape the neck of the bag separately, with additional glass filament reinforced tape of the same kind. The total mass of the impactor assembly shall be 45.4 kg \pm 0.2 kg (100 lb \pm 4 oz.) as described in Figure 13, excluding traction system attachments.

To reduce bag deformation during testing, the bag shall be rotated about the axis of its suspension device before each specimen or sample set, by no less than 30 degrees, and by no more than 90 degrees.

NOTE To reduce bag damage during testing, a thin homogeneous or non-woven plastic film no more than 0.13 mm (0.005 in.) thick or a loosely draped woven cloth towel weighing no more than 0.05 g/cm² (0.0113 oz./in²) may be suspended vertically in front of the surface of the specimen at a distance no more than 10 mm (2/5 in.).

The impactor shape shall be maintained constant during testing. To reduce visible deformation of the impactor, it shall be removed from the suspension device and pummelled with a rubber mallet into its approximate original shape.

¹ Such as 3M No. 898 (a trade name), or equal. As of the date of publication of this version, Everlast no longer supplies these bags. A source of supply is the Safety Glazing Certification Council (SGCC) at www.sgcc.org.

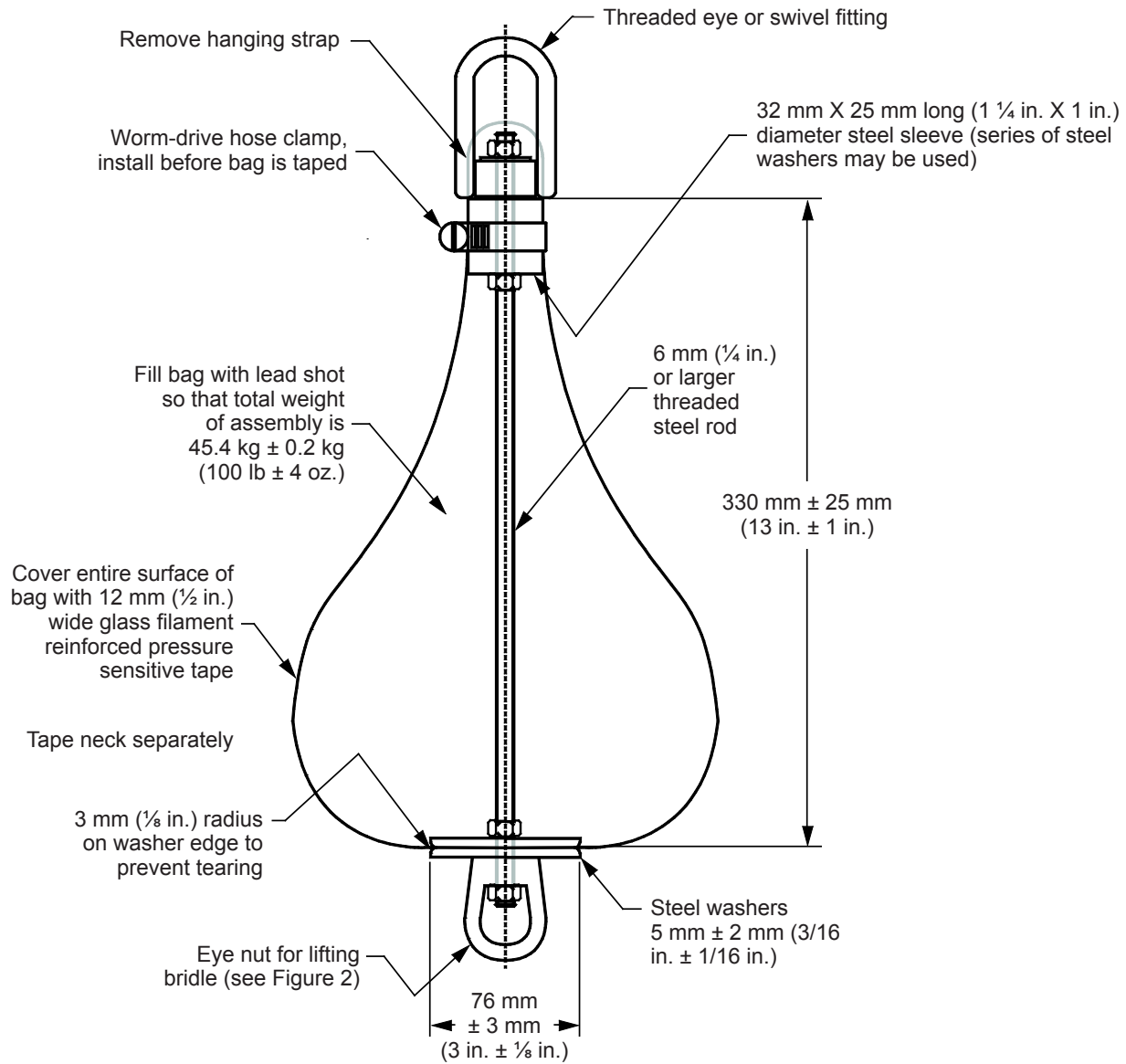

Figure 13 – Impactor

10.1.1.4 Suspension device

The impactor is suspended by means of a single, stranded-steel cable, approximately 3 mm (1/8 in.) diameter, from an upper swivel-fixture above the head of the main frame at an elevation of which the minimum distance between the swivel-fixture and impactor centreline is 1524 mm (60 in.). The upper swivel-fixture shall be rigid to ensure the point of suspension remains stationary. The lower swivel(s) or equivalent shall be provided on the bag for rotation of the impactor about its suspension device axes between impact events.

When at rest, the surface of the impactor, at its maximum diameter, shall be located no more than 51 mm (2 in.) from the surface of the specimen and no more than 51 mm (2 in.) from the centre of the specimen.

10.1.1.5 Traction and release system

A traction system shall be used which enables the impactor to be brought into its launch position. The launch position depends on the drop height selected. The traction cable is connected to the impactor traction system by a release mechanism, with provisions for rotating the impactor.

To position the impactor at the selected drop height, a traction force shall be applied to raise the impactor such that the axis of the impactor shall be aligned with the suspension cable, with the cable remaining taut. To ensure this, the top and bottom ends of the impactor shall be connected to the release device by a suitable link.

10.1.2 Impact classification

Glazing materials shall be submitted for impact testing to a selected drop height class.

10.1.2.1 Drop height class

Glazing materials conforming to this standard are classified by their performance under the impact test at the selected drop height.

- a) Class A — Glazing material that complies with the requirements of 10.1.4 when tested in accordance with the procedure in 10.1.3 at a drop height between 1219 mm and 1232 mm (48 in. and 48½ in.) using an impact specimen appropriate to the size classification.
- b) Class B — Glazing material that complies with the requirements of 10.1.4 when tested in accordance with the procedure in 10.1.3 at a drop height of between 457 mm and 470 mm (18 in. and 18½ in.) using an impact specimen appropriate to the size classification.

10.1.2.2 Drop height qualification

Glazing material qualified for classification at the higher impact drop height level Class A, shall be deemed to comply with the lower impact drop height level Class B.

10.1.3 Impact procedure

- a) Place and centre each specimen in the sub-frame so each edge is encased in the elastomeric rubber strip to a depth of at least 10 mm (2/5 in.). With the specimen mounted, the elastomeric rubber strip shall not be compressed by more than 15% of its thickness. For bolts, torque shall be 20 Nm + 5 Nm (15 ft-lb. + 4 ft-lb).
- b) Select a drop height classification from 10.1.2.1. Rotate the impactor as required. Raise the impactor to the selected drop height intended for classification and stabilize it. At the selected drop height, the suspension device shall be taut and the axes of the impactor and cable shall be in line.
- c) The impactor, stabilized in the launch position in a vertical plane normal to the test specimen, is released and falls without initial velocity or axial rotation. At least one impact shall occur on each test specimen. Unbroken specimens may be reused for higher classification impact testing.
- d) Classify the test specimen in accordance with the glazing in Table 2. Inspect each test specimen after impact and record and report whether it complied or did not comply with the Applicable Interpretation of Results contained in Table 2. If classified as Tempered glass, open the sub-frame to allow any particles to be released and fall free.
- e) If any of the required specimens fail to comply with the requirements of 10.1.4, the material shall not be classified for impact.
- f) For asymmetric materials, the test shall be carried out on both sides using equal numbers of separate specimens.

- g) When the required number of specimens is impacted and inspected, report the impact classification as described in 10.1.2. If all specimens tested by impact either do not break, or break according to the requirements of 10.1.4, the glazing material shall be classified as described in 10.1.2, at the impact level tested. Classification shall comprise the word “Class”, followed by a letter designation (“A” or “B”) for drop height class (see 10.1.2.1).
- h) If it is required to test the material to a higher impact classification level, repeat the test on the required number of undamaged specimens of the same material at the higher impact level. At the fabricator’s discretion, previously tested but unbroken specimens may be used for higher impact classification testing.
- i) Each specimen of bent glass will be impacted on the convex surface at the centre of the specimen perpendicular to the frame from the selected drop height (see Figure 7).

NOTE The convex surface is tested due to the realistic constraints of the test set-up in impacting the concave surface. Additionally, as of the date of this publication, no data was available that showed one surface is more or less likely to break during impact.

Table 2 – Applicable interpretation of results for shot bag impact

Interpretation of results	Laminated glazing	Fully tempered glass	Organic coated glazings	Plastic glazing
Type (1)	X		X	
Type (2)		X		
Type (3)				X
Type (4)	X	X	X	X

10.1.4 Acceptance criteria

Evaluation after impact shall occur whether the specimen remains fully engaged in the frame or partially engaged in the frame, or is entirely disengaged from the frame. A glazing material shall be judged to pass the impact test if any one of the applicable acceptance criteria below is met by each of the required number of impact specimens tested.

10.1.4.1 Type (1)

Upon impact, one or more cracks may appear. Fragments tend to be contained by the interlayer or adhesive-like laminated or organic-coated glazing.

Specimen acceptance criteria: No tear or shear or opening develops within the vertical specimen through which a 76 mm (3.0 in.) diameter sphere can pass using a horizontally applied force of 18 N (4.0 lb.) or less. Additionally, if particles are detached from the test specimen (including particles that might be retained in the frame under the stops), up to 3 min after impact, they shall, in total, weigh no more than a mass equivalent to 10 000 mm² (15.5 in²) of the original test piece. The single largest particle shall weigh less than a mass equivalent to 4400 mm² (6.82 in²) of the original test piece. Detached individual particles less than the mass equivalent of 650 mm² (1 in²) shall be excluded from the fragment analysis.

10.1.4.2 Type (2)

Upon impact, the specimen shatters like fully tempered glass.

Specimen acceptance criteria: The ten largest crack-free particles shall be selected within 5 min subsequent to the impact and shall weigh no more than the equivalent weight of 6452 mm² (10 in²) of the original specimen. For purposes of impact test acceptance when breakage occurs, the average thickness of a fully tempered glass specimen containing grooves, bevels, or other thickness altering fabrication shall be considered the average of the

thinnest measurement of each of the ten geometrically largest crack-free particles. This average thickness will then be used to determine the maximum allowable weight of the ten largest crack-free particles.

NOTE For soda lime glass, the weight in ounces of 6452 mm² (10 in²) is equal to 14.5 times the glass thickness in inches. The weight in grams of 6452 mm² (10 in²) of glass is equal to 412 times the glass thickness in inches (16.18 g/mm).

10.1.4.3 Type (3)

Upon impact, the specimen breaks like plastic glazing.

Specimen acceptance criteria: The stiffness and hardness of the specimen shall be determined. A modulus of elasticity (see ASTM D790) less than 3.9 GPa (550 000 psi) and a Rockwell hardness (see ASTM D785) less than M or R 140 shall indicate satisfactory compliance.

10.1.4.4 Type (4)

Upon impact, the specimen does not break.

Specimen acceptance criteria: No breakage occurs. For tempered glass, the specimen shall meet 10.2.

10.2 Centre punch fragmentation test

This test is only used to evaluate fully tempered glass specimens that do not break during the impact test of 10.1.

This test is to be performed in addition to the test described in 10.1. Specimens for testing shall have been previously tested per 10.1. Specimens temperature shall be between 18.3°C and 29.4°C (65°F and 85°F) prior to testing.

10.2.1 Equipment

The following equipment is required:

- a) A **sharp impactor** such as a pointed hammer of about 75 g (2.65 oz.) mass, or a spring-loaded centre punch or similar appliance can be used.
- b) A **means of specimen support** consisting of a flat base with adjustable horizontal curbs to prevent scattering of fragments.
- c) A **calibrated scale** suitable for accurately weighing selected particles to the nearest 0.1 g (0.004 oz.).
- d) A **calibrated micrometer** capable of measuring the thickness of the selected specimen/particle.

10.2.2 Procedure

- a) **Flat glass:** Place the specimen on the flat base and place the curb lightly along the specimen edges so the sample can elongate slightly yet the fragments remain interlocked.
- b) **Bent glass:** Place the specimen on the bent glass impactor frame on a flat base with the convex side facing up. The specimen shall have edges continuously supported.
- c) Strike the test specimen 25 mm (1 in.) inboard of the longest edge at its midpoint until fracture occurs.

10.2.3 Particle weight determination

Within 5 min after fracture, collect and weigh the ten largest crack-free particles. In the event any of the ten largest particles cracks after original selection, all pieces shall be weighed.

For transparent flat glass, measure the thickness of the largest particle. For patterned glass thickness measurement, see ASTM C1036 for thickness measurement technique. Record the thickness.

NOTE Some applications may require a particle count in accordance with BS EN 12150².

10.2.4 Centre punch fragmentation interpretation of results

The total weight of the ten largest crack-free pieces shall weigh no more than the equivalent weight of 6452 mm² (10 in²) of the original test sample.

NOTE For soda lime glass, the weight in ounces of 6452 mm² (10 in²) is equal to 14.5 times the glass thickness in inches. The weight in grams of 6452 mm² (10 in²) of glass is equal to 412 times the glass thickness in inches (16.18 g/mm).

No one particle shall be longer than 102 mm (4 in.) excluding an area of radius 102 mm (4 in.) centred on the impact point, and a border of 25 mm (1 in.) around the entire perimeter/edge of the test specimen (see Figure 14).

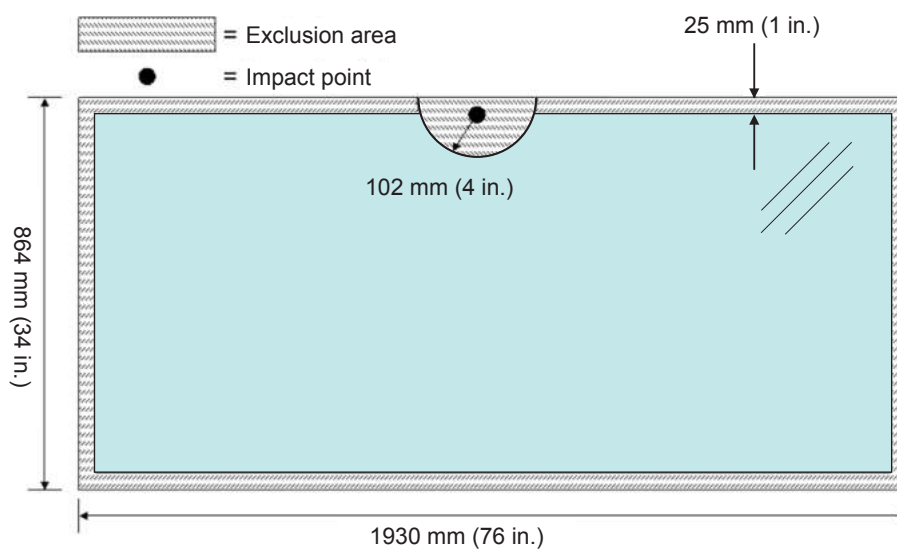

Figure 14 — Centre punch fragmentation

If any of the required specimens fail to comply with the requirements of 10.2.3, the material shall not be classified for impact.

10.3 Thermal test for laminated and organic coated glazings

This test shall be made to determine the probable effect of exposure to high temperature and humidity conditions for a long period of time.

10.3.1 Procedure

Three 305 mm x 305 mm (12 in. x 12 in.) flat specimens, as submitted, shall be subjected to an extended heat history through bake testing in an oven or boil testing. The thermal test may be conducted either in a heating

² The publication BS EN 12150 is available from <http://shop.bsigroup.com>.

chamber or boiling water. The test temperature is $100\text{ }^{\circ}\text{C} \pm 2^{\circ}\text{C}$ ($212^{\circ}\text{F} \pm 4^{\circ}\text{F}$). The specimens shall be conditioned to a uniform test temperature between 18°C and 29°C (65°F and 85°F) for at least 4 h with separation to permit free air circulation prior to rating. Thermal test only applies to organic coated glazings that are used for exterior glazing.

10.3.1.1 Boil testing

Samples are immersed, vertically, in water at $65.6^{\circ}\text{C} \pm 6^{\circ}\text{C}$ ($150^{\circ}\text{F} \pm 10^{\circ}\text{F}$) for 3 min and then quickly transferred to and similarly immersed in boiling water. The specimens shall be kept in boiling water for 2 h and then removed.

10.3.1.2 Bake testing

Samples are placed in a preheated chamber with samples not contacting the walls of the chamber and allowing for free flow of air around each specimen with the exception of the racking mechanism. The chamber is allowed to regain set temperature and test is maintained at temperature for 16 h.

10.3.2 Acceptance criteria

The glass itself may crack in this test, but no bubbles or delaminations shall develop more than 12 mm (1/2 in.) from the outer edge of the specimen or from any crack that may develop. Any specimen in which, the glass cracks to an extent confusing the results shall be discarded without prejudice, and another specimen shall be tested instead.

10.4 Weathering tests for laminated, organic coated and plastic glazings

The purpose of these tests is to determine whether these safety-glazing materials will successfully retain their safety characteristics after exposure to weathering conditions for an extended period of time. The weathering methods described in 10.4.1 shall be used for all materials subjected to exterior exposure. After weathering, organic coated glass shall be tested as described in 10.4.2.1 and 10.4.2.2; laminates shall be tested as described in 10.4.2.1 and 10.4.2.3, and plastics shall be tested as described in 10.4.2.4 in order to evaluate whether or not the safety glazing meets the weathering requirements. Plastic, organic coated or laminated materials intended for interior use only shall be subjected only to the aging requirements in 10.4.3.

10.4.1 Weathering methods

The specimens shall be subjected to one of the two following weathering exposures. For laminated, plastics and organic coated glazings, three specimens with the side marked for exterior exposure shall be exposed to the energy source. Three additional specimens shall be controls and shall be held in darkness at $23^{\circ}\text{C} \pm 2^{\circ}\text{C}$ ($73.4^{\circ}\text{F} \pm 3.6^{\circ}\text{F}$) until needed (see 10.4.2.2 and 10.4.2.3). For plastics, see 6.4.1.

10.4.1.1 Natural exposure

- a) Procedure: The specimens shall be exposed in accordance with ASTM D1435 using a 26° North latitude, 45° angle of exposure, direct, facing South, open-backed mounting.
- b) Location: The specimens shall be tested in a location where one year natural exposure approximates $300 \pm 25\text{ MJ/m}^2$ at 295-385 nm, such as South Florida, United States of America or an alternate location.
- c) Duration: The specimens shall be exposed for one year. On average, a one-year exposure approximates a Total Ultraviolet (TUV) exposure of $300 \pm 25\text{ MJ/m}^2$ at 295-385 nm.

10.4.1.2 Accelerated exposure for building envelope glazing

- a) Apparatus: The specimens shall be subjected to exposure in a Xenon-arc type operating light apparatus as specified in ASTM G155 with filters and in accordance with section 6.1.3 *Spectral Irradiance of Xenon Arc with Daylight Filters*.

- b) Procedure: The specimens shall be exposed in accordance with ASTM D2565 (or ISO 4892-2) and the following conditions as stated in Table 3:

Table 3 – Accelerated weathering conditions

Parameter	Description
ASTM D2565 Cycle	Cycle 1
Black panel temperature	64°C ± 2°C (145°F ± 4°F)
Relative humidity	50% ± 5%
Spray water	De-ionized
Irradiance ^a	0.35 ± 0.02 W/m ² @ 340 nm, or 41.5 ± 2.5 W/m ² from 300 – 400 nm
Exposure duration ^a	3000 h

^a Minimum acceptable levels of irradiance and duration are indicated and shall be recorded in the report section. Higher irradiance levels and longer duration are permitted and shall be recorded in the report section.

10.4.1.3 Laminated and organic coated glazings weathering

The purpose of weathering laminated and organic coated glazings is to determine if degradation of the interlayer or organic coating occurs over the duration of the exposure. Surface etching of the glazing may occur in the accelerated chamber or on natural exposure and erroneously indicate interlayer or adhesive changes. An identical piece of glazing material from which the laminates have been manufactured, a blank (i.e.: glass, plastic etc.), may be weathered concurrently to determine the weathering of glazing and eliminate those changes from the interlayer or adhesive evaluation.

10.4.2 Tests after weathering

Specimens exposed in accordance with 10.4.1 shall be tested after weathering according to the procedures outlined in 10.4.2.1 and 10.4.2.2. For organic coated glass, see 10.4.2.1; for laminates, see 10.4.2.1 and 10.4.2.3; and for plastics, see 10.4.2.4.

10.4.2.1 Laminated and organic coated materials

Assessment of optical changes after weathering are included for laminated and organic coated materials as significant changes can be indicative of product degradation which may have an effect on impact and safety performance. Changes in the blank glazing (see 10.4.1.3) based on the comparison of non-weathered retain data shall be deducted from the weathered laminated or organic coated specimens for evaluation of the properties listed in 10.4.2.2.

- a) Measurement location: Specimens shall be measured at a point more than 10 mm inward from any edge.
- b) Acceptance criteria: When compared to control (unexposed) samples, no weathered specimen shall exhibit more than the allowable change, as specified, for the following properties:
- 1) Visible light transmittance change not greater than 5 percentage units (e.g.: 91% control ± 5% = 96% or 86%) as measured in accordance with ASTM D1003;.
 - 2) Yellowness index (for clear products only) increase not greater than 0.5 YI units (e.g.: 0.70 YI control + 0.5 = 1.20) as measured in accordance with ASTM E313;.

- 3) Haze increase not greater than 0.5 percentage units (e.g.: 0.70 control \pm 1.20) as measured in accordance with ASTM D1003;
- 4) Delta E less than or equal to 5 units as measured in accordance with ASTM E308; and calculated in accordance with ASTM D2244, section 6.2.1.

10.4.2.2 Organic coated glazing only

Organic coated glazing specimens shall be judged satisfactory if they pass the requirements of 10.4.2.1, adhesion test (see 10.4.2.2.1) and the tensile strength test (see 10.4.2.2.2).

10.4.2.2.1 Adhesion test

- a) Specimens: Six specimens, [nominally 52 mm x 152 mm (2 in. x 6 in.)] prepared as described in 6.4.2 shall be tested. The specimens shall be conditioned just prior to the performance of the adhesion test at 23°C \pm 2°C (73.5°F \pm 3.5°F) and 50% \pm 2% relative humidity for 24 h.
- b) Apparatus: The test apparatus shall be 1) a tensile tester of the constant-rate-of-extension (CRE) type with the moving crosshead set to move at 305 mm (12 in.) per minute and the load range set so that the average peel force will fall at 30%-50% of full scale and 2) a cutting device containing new razor blades for cutting 25 mm (1 in.) wide specimens (use each blade one time only).
- c) Procedure: Using the 25 mm (1 in.) razor cutting device, cut a straight strip of the organic coating in the lengthwise direction of the specimen. Peel back about 52 mm (2 in.) of one end of the 25 mm (1 in.) wide organic strip. Attach a strip of pressure-sensitive tape to the side of the organic strip opposite the adhesive to extend this free end to about 203 mm (8 in.) in length. Place the end of the glass panel from which the organic strip was removed in the lower clamp of the tensile tester and the free end of the tape in the upper clamp. Peel the remainder of the organic strip from the glazing mechanically and obtain a record of the peel value. Determine the average pull for each specimen from the chart record.
- d) Acceptance criteria: The organic coated glass adhesions shall be judged satisfactory if the average adhesion value of the three exposed specimens is no less than 75% of the average adhesion value of the three control (unexposed) specimens.

10.4.2.2.2 Tensile strength test

- a) Specimens: The samples for this test are the same specimens used in the adhesion test (see 10.4.2 a) and conditioned as in 10.4.2.1 a).
- b) Apparatus: The test apparatus shall be 1) a CRE tensile tester set as follows: gage length - 52 mm (2 in.); crosshead speed - 52 mm (2 in.) per minute; load range - set full-scale load so that specimens will break at 30%-60% of full scale and 2) a cutter containing new razor blades for cutting 12 mm (1/2 in.) wide specimens (use each blade one time only).
- c) Procedure: Using the 12 mm (0.5 in.) razor cutting device, cut a straight strip of the organic coating in the lengthwise direction of the glass sample for the full 152 mm (6 in.) length. Carefully peel this strip from the glass panel and test it for breaking strength in the tensile strength tester.
- d) Acceptance criteria: The organic-coating tensile shall be judged satisfactory if the average tensile value of the three exposed specimens is no less than 75% of the average tensile value of the three control specimens.

10.4.2.3 Laminated and organic glazing only

- a) Specimens: After exposure, the test specimens may be cleaned, if necessary, using a procedure recommended by their manufacturer to remove any residues present.

- b) Conditioning: Both the unexposed and exposed specimens shall be conditioned prior to examination or further testing for a minimum of 48 h at 22°C to 24°C (71°F to 75°F) and 50% ± 2% relative humidity.
- c) Viewing: When irradiated and conditioned, the exposed specimens shall be examined and compared visually with the unexposed controls. Specimens shall be placed in a vertical position. The viewer shall look through the specimen using daylight without direct sunlight, or using a background light suitable for observing blemishes. View at 910 mm (36 in.).
- d) Acceptance criteria: Any improvement in clarity or discoloration is acceptable. When examined after ultraviolet exposure, each exposed test specimen shall meet the criteria of 10.4.2.1.1 and be substantially free of noticeable decomposition as defined by absence of the following specific kinds of developed defects or blemishes, when observed by this inspection method in comparison to unexposed control specimen(s):
 - 1) No bubbles or delamination shall be visible more than 10 mm (0.4 inch) from any outer edge of the specimen, and
 - 2) No crazing or cracking is allowed.
 - 3) If no noticeable decomposition and no other defects develop upon exposure, the glazing material shall be reported as visually acceptable. Otherwise, unacceptable glazing material shall be reported as visually blemished.
- e) Interpretation of weathering results: When the thinnest construction of all components of laminated and organic coated glazings have passed the applicable weathering requirements and subsequent evaluation as stated in 10.4, thicker components and coloured components of the same material are deemed as qualified for weathering compliance.

10.4.2.4 Plastics only

- a) Specimens: shall be evaluated before and after exposure in accordance with ASTM D6110, Charpy Impact Test, Method B, with the following exceptions:
 - 1) The specimens shall not be notched.
 - 2) The specimens shall be tested with the exposed surface in tension.
 - 3) The specimens shall be exposed and tested flatwise.
 - 4) The span shall be reduced to 52 mm (2 in.) for thin material that may slip through the supports without breaking.
 - 5) The average of four samples taken from the weathered specimens shall be reported. A fifth sample shall be retained unexposed as a control.
- b) Acceptance criteria: Plastic materials shall be acceptable for use as safety glazing if the impact strength as measured by the Charpy Impact Test is not reduced by more than 25% as a result of the natural or accelerated exposure. No bubbles or other physical degradation shall develop in the exposed portion.

10.4.3 Indoor applications only – Aging tests for laminates, plastics and organic coated glazing, and mirror glazing

The purpose of these tests is to determine whether laminates, plastic, organic coated glazing and mirror glazing for indoor use only will successfully retain their safety characteristics after exposure to simulated aging conditions for an extended period of time. The specimens described in 7.4 for impact test after aging shall be used. Specimen size shall be in accordance with 4.6. Specimens passing the requirements of natural or accelerated exposure (see 10.4.1) and subsequent testing (see 10.4.2) are deemed qualified for indoor applications without further evaluation.

10.4.3.1 Accelerated exposure

- a) Apparatus: The specimens shall be subjected to exposure in a Xenon-Arc Type Operating Light Apparatus as specified in ASTM G155 with filters in accordance with ASTM D4459.
- b) Procedures: The specimens shall be exposed in accordance with ASTM D4459 and the following conditions as indicated in Table 4.

Table 4 — Accelerated weathering conditions – Indoor product use

Parameter	Description
Light Mode	Continuous
Black panel temperature	55° ± 2°C (131° ± 4°F)
Relative humidity	55% ± 5%
Spray water	None
Irradiance ^a	0.3 ± 0.02 W/(m ² * nm)@ 340 nm, or 0.8 ± 0.05 W/(m ² * nm) @ 420 nm, or 36.5 ± 2.5 W/m ² between 300 and 400 nm
Exposure duration ^a	3000 h
^a Minimum acceptable levels of irradiance and duration are indicated and shall be recorded in the report section. Higher irradiance levels and longer duration are permitted and shall be recorded in the report section.	

c) Acceptance criteria:

1) Aging tests for plastics used in indoor applications only

After exposure in accordance with 10.4.3.1, specimens passing the requirements in 10.4.2 are qualified for indoor applications.

2) Aging tests for laminates and organic coated glazing used in interior applications only

After exposure in accordance with 10.4.3.1, specimens passing the requirements in 10.4.2.1.1 are qualified for indoor applications.

3) Aging tests for mirror glazing used in interior applications only

i) Apparatus: A conditioning chamber of sufficient size to hold up to 864 mm x 1930 mm (34 in. x 76 in.) panels vertically and capable of maintaining conditions of 60°C ± 3°C (140°F ± 5°F), 38°C ± 3°C (100°F ± 5°F) and 95% ± 5% relative humidity, and 18°C ± 3°C (0°F ± 5°F).

ii) Procedure: Place four of the organic coated glazing specimens positioned vertically and spaced at least 25 mm (1 in.) apart in the chamber. Raise the temperature to 60°C ± 5°C (140°F ± 5°F) within 3 h and maintain for 21 h. Change the chamber conditions to 38°C ± 3°C (100°F ± 5°F) and 95% ± 5% relative humidity in 3 h and maintain for 21 h. This represents one complete cycle. Expose the specimens to ten complete cycles. At the completion of the tenth cycle, change the chamber conditions to 18°C ± 3°C (0°F ± 5°F) in 3 h and maintain for 21 h. The fifth specimen shall be retained unexposed as a control for the effects of the exposure cycling. Upon completion of the required number of exposure cycles, all specimens shall be tested as described in 10.1.1.

- 4) Impact test after aging for mirror glazing
 - i) Apparatus: The apparatus described in 10.1.1 shall be used.
 - ii) Procedure: All the specimens exposed as described in 10.4.3 shall be conditioned as described in 10.1 and evaluated by the procedure in 10.1.2.
 - iii) Acceptance criteria: The exposed specimens shall again satisfactorily complete the impact test in accordance with 10.1.3. Milkiness may develop but defects other than these shall be cause for rejection.

Annex A *(informative)*

Areas of human impact

A.1 General

Areas of human impact include, but may not be limited to, doors, glazed panels adjacent to doors, glazed exterior/interior passageway doors, storm (combination) doors, guards, patio doors, and shower and bathtub doors and their enclosures.